

---

# Mounting and Dismounting of Rolling Bearings

**FAG**

Rolling Bearings

---

FAG Bearings Sales Corporation/FAG Bearings Limited

WL 80 100/3 EC/ED



# **Mounting and Dismounting of Rolling Bearings**

**Publ. No. WL 80 100/3 EC/ED**

## **FAG Bearings Sales Corporation**

200 Park Avenue,  
Danbury, CT 06813

## **FAG Bearings Limited**

2871 Plymouth Drive  
Oakville, Ontario L6H 5S5  
Tel. 905/829-2750

Rolling bearings are heavy-duty machine elements with high-precision components. In order to fully utilize their capacity, the design engineer must select the right bearing type and design and match the bearing properties to those of the mating components. Mounting and dismounting, lubrication, sealing and maintenance must also be given special attention.

Appropriate means for mounting and dismounting of rolling bearings as well as utmost cleanliness and care at the assembly site are necessary in order to enable the bearings to reach a long service life.

This publication is intended to inform bearing servicemen and maintenance men on handling, mounting and dismounting, lubrication and maintenance of rolling bearings. A special chapter deals with bearing failures and their causes. The tables in the annex specify bearing numbers, tolerances of bearings and their mating components, bearing clearance and FAG rolling bearing greases Arcanol.

For information on special mounting and dismounting tools and methods and on measuring instruments, further publications are available. Bearing mounting problems beyond the scope of this publication should be referred to our Engineering Service.









































# Table of Contents











































1.	<b>Rolling bearing storage</b> . . . . .	8
2.	<b>How to prepare rolling bearings for mounting and dismounting</b> . . . . .	9
2.1	Work planning . . . . .	9
2.2	The „right“ bearing . . . . .	9
2.3	Handling of rolling bearings before mounting . . . . .	10
2.4	Cleanliness in mounting . . . . .	10
2.5	Surrounding parts . . . . .	11
2.6	Fits . . . . .	11
2.7	Inspection of bearing seats . . . . .	12
2.7.1	Cylindrical seats . . . . .	12
2.7.2	Tapered seats . . . . .	15
3.	<b>Rolling bearing mounting</b> . . . . .	18
3.1	Mechanical methods . . . . .	18
3.1.1	Mounting of cylindrical bore bearings . . . . .	18
3.1.2	Mounting of tapered bore bearings . . . . .	24
3.2	Thermal methods . . . . .	29
3.2.1	Heating plate . . . . .	30
3.2.2	Oil bath . . . . .	30
3.2.3	Hot air cabinet . . . . .	32
3.2.4	Induction heating device . . . . .	32
3.2.5	Induction coil . . . . .	34
3.2.6	Cooling . . . . .	35
3.3	Hydraulic method . . . . .	36
3.4	Clearance adjustment on mounting . . . . .	40
3.4.1	Angular contact ball bearings and tapered roller bearings . . . . .	40
3.4.2	Thrust bearings . . . . .	46
3.4.3	Machine tool bearings . . . . .	46
4.	<b>Rolling bearing dismounting</b> . . . . .	51
4.1	Mechanical methods . . . . .	52
4.1.1	Dismounting of cylindrical bore bearings . . . . .	52
4.1.2	Dismounting of tapered bore bearings . . . . .	55
4.1.2.1	Dismounting of adapter sleeve mounted bearings . . . . .	55
4.1.2.2	Dismounting of withdrawal sleeve mounted bearings . . . . .	56
4.2	Thermal methods . . . . .	57
4.2.1	Heating ring . . . . .	57
4.2.2	Induction coil . . . . .	58
4.2.3	Ring burner . . . . .	59
4.3	Hydraulic method . . . . .	60
4.3.1	Dismounting of tapered bore bearings . . . . .	61
4.3.2	Dismounting of cylindrical bore bearings . . . . .	63

# Table of Contents

5.	<b>Lubrication</b> .....	65
5.1	Greases .....	65
5.2	Oils .....	66
5.3	Selection of lubricant .....	66
6.	<b>Rolling bearing damage</b> .....	70
6.1	Why does a bearing fail? .....	71
6.1.1	Faulty mounting .....	71
6.1.2	Contamination .....	73
6.1.3	Corrosion .....	74
6.1.4	Passage of electric current .....	75
6.1.5	Imperfect lubrication .....	75
6.2	How to recognize bearing damage in operation? .....	77
6.3	How to pinpoint bearing damage? .....	78
6.3.1	Observations prior to dismounting .....	78
6.3.2	Observations during dismounting .....	79
6.3.3	Bearing inspection .....	81
7.	<b>Tables</b> .....	83
7.1	Bearing designation .....	83
7.2	Designation of bearing series .....	84
7.3	Shaft tolerances .....	86
7.4	Housing tolerances .....	90
7.5	Normal tolerances of FAG radial bearings (except tapered roller bearings) .....	94
7.6	Normal tolerances of FAG tapered roller bearings .....	96
7.7	Normal tolerances of FAG thrust bearings .....	97
7.8	Limit dimensions of chamfer .....	98
7.9	Radial clearance of FAG deep groove ball bearings .....	100
7.10	Radial clearance of FAG self-aligning ball bearings .....	101
7.11	Radial clearance of FAG cylindrical roller bearings .....	102
7.12	Radial clearance of FAG spherical roller bearings .....	104
7.13	Radial clearance of FAG barrel roller bearings .....	106
7.14	Axial clearance of FAG double row angular contact ball bearings (series 32 and 33) .....	107
7.15	Axial clearance of FAG four-point bearings .....	108
7.16	Radial clearance reduction of FAG cylindrical roller bearings with tapered bore .....	109
7.17	Radial clearance reduction of FAG spherical roller bearings with tapered bore .....	110
7.18	FAG rolling bearing greases Arcanol .....	111
	Rolling bearing mounting cabinet and mounting sets – Fundamental course for vocational training .....	112
	Selection of FAG publications .....	113

# Chart: Tools and Methods for Mounting and Dismounting

Bearing type		Bearing bore	Bearing size	Mounting				without heating		
				with heating						
	Deep groove ball bearing Magneto bearing		Tapered roller bearing	cylindrical	small					
	Angular contact ball bearing Spindle bearing		Barrel roller bearing		medium					
	Four-point bearing		Spherical roller bearing		large					
	Self-aligning ball bearing									
	Cylindrical roller bearing			cylindrical	small					
	Needle roller bearing				medium					
					large					
	Thrust ball bearing			cylindrical	small					
	Angular contact thrust ball bearing				medium					
	Cylindrical roller thrust bearing				large					
	Spherical roller thrust bearing									
	Self-aligning ball bearing Self-aligning ball bearing with adapter sleeve			tapered	small					
	Barrel roller bearing Barrel roller bearing with adapter sleeve				medium					
	Spherical roller bearing Spherical roller bearing with adapter sleeve Spherical roller bearing with withdrawal sleeve		Withdrawal sleeve		large					
	Cylindrical roller bearing, double row			tapered	small					
					medium					
					large					

	Hydraulic method	Dismounting		Hydraulic method	Symbols
		with heating	without heating		
			  		 Oil bath  Heating plate  Hot air cabinet
		 	 		 Induction heating device  Induction coil  Heating ring  Hammer and mounting sleeve
			 		 Mechanical and hydraulic presses  Double hook wrench  Nut and hook wrench
 			 	 	 Nut and thrust bolts  Axle cap  Hydraulic nut
			  	 	 Hammer and metal drift  Extractor  Hydraulic method

# 1. Rolling Bearing Storage

## 1: Rolling bearing storage

- a: Large bearings especially should not be stored upright.
- b: They should be stored flat and supported over their entire circumference.

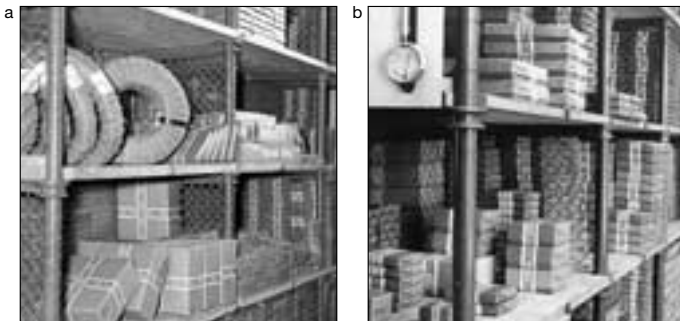

### Leave bearings in their original package

Store bearings in their original package in order to protect them against contamination and corrosion. Open package only at the assembly site immediately prior to mounting.

### Store larger bearings flat

Larger bearings with relatively thin-walled rings should not be stored upright (Figure 1a) but flat and supported over their whole circumference (Figure 1b).

Prior to packing, FAG rolling bearings are dipped in anticorrosive oil. This oil does not gum and harden and is compatible with all commercial rolling bearing greases. In their original package rolling bearings are safely protected against external influences.

### Store bearings in dry rooms

During storage, the bearings must not be exposed to the effects of aggressive media such as gases, mists or aerosols of acids, alkaline solutions or salts. Direct sunlight should be avoided. The formation of condensation water is avoided under the following conditions:

- Temperatures + 6 to + 25 °C,  
for a short time 30 °C
- temperature difference day/night  $\leq 8$  K,  
relative air humidity  $\leq 65$  %.

With standard preservation, bearings can be stored up to 5 years if the said conditions are met.

If the permissible storage period is exceeded, it is recommended to check the bearings for its preservation state and corrosion prior to use. On request, FAG will help to judge the risk of longer storage or use of older bearings.

Bearings with shields or seals on both sides should not be kept to their very limit of storage time. The lubricating greases contained in the bearings may change their chemico-physical behaviour due to aging (see FAG catalogue WL 41 520).

# 2. How to Prepare Rolling Bearings for Mounting and Dismounting

## 2.1 Work Planning

Prior to mounting and dismounting of rolling bearings, several preparatory steps should be taken.

Study the shop drawing to familiarize yourself with the design details of the application and the assembly sequence. Phase the individual operations and get reliable information on heating temperatures, mounting and dismounting forces and the amount of grease to be packed into the bearing.

Study shop drawing and phase individual operations

Whenever rolling bearing mounting and dismounting require special measures, the bearing serviceman should be provided with comprehensive instructions on mounting details, including means of transport for the bearing, mounting and dismounting equipment, measuring devices, heating facilities, type and quantity of lubricant.

## 2.2 The „Right“ Bearing

Prior to mounting, the bearing serviceman must make sure that the bearing number stamped on the package agrees with the designation given on the drawing and in the parts list. He should therefore be familiar with the bearing numbering and identification system (see tables 7.1 and 7.2, pp. 83 to 85).

Compare inscription on package with data on drawing

Standard bearings are identified by the bearing number listed in the pertinent standards and rolling bearing catalogues. Its structure is a system of numerals and letters. The first group in the system identifies the bearing type and diameter series, also the width series for some bearings. The second group constitutes the bore reference number; for bearings of 20 to 480 mm bore, the actual bore diameter in millimetres is five times the bore reference number.

If operating conditions call for a bearing with special design features, the required bearing characteristics are indicated by suffixes added to the bearing number (see table 7.1, p. 83).

Non-standardized FAG bearings are identified by code numbers from the 500 000 or 800 000 series.

# Preparations

## 2.3 Handling of Rolling Bearings before Mounting

FAG rolling bearings are preserved in their original package, with an anticorrosive oil. The oil need not be washed out, when mounting the bearing. In service, the oil combines with the bearing lubricant and provides for sufficient lubrication in the run-in period.

The seats and mating surfaces must be wiped clean of anticorrosive oil before mounting.

Wash out anticorrosive oil with cold-cleaning agent from tapered bearing bores prior to mounting in order to ensure a safe and tight fit on the shaft or sleeve. Then thinly coat the bore with a machine oil of medium viscosity.

Prior to mounting, wash used and contaminated bearings carefully with kerosene or cold-cleaning agent and oil or grease them immediately afterwards.

Do not perform any rework on the bearing. Subsequent drilling of lubrication holes, machining of grooves, flats and the like will disturb the stress distribution in the ring resulting in premature bearing failure. There is also the risk of chips or grit entering the bearing.

Wipe clean seats and mating surfaces of anticorrosive oil

Wash out used and contaminated bearings

Do not rework rings

## 2.4 Cleanliness in Mounting

Absolute cleanliness is essential! Dirt and humidity are dangerous offenders, since even the smallest particles penetrating into the bearing will damage the rolling surfaces. The work area must, therefore, be dust-free, dry and well removed from machining operations. Avoid cleaning with compressed air.

Ensure cleanliness of shaft, housing and any other mating parts. Castings must be free from sand. Bearing seats on shaft and in housing should be carefully cleaned from anti-rust compounds and residual paint. Turned parts must be free from burrs and sharp edges. After cleaning, the housing bore should receive a protective coating.

Keep work area dust-free and dry

Wipe clean seats and mating surfaces of anticorrosive oil

## 2.5 Surrounding Parts

All surrounding parts should be carefully checked for dimensional and form accuracy prior to assembly

**Check mating parts for dimensional and form accuracy prior to bearing mounting**

Non-observance of the tolerances for shaft and housing seat diameters, out-of-roundness of these parts, out-of-square of abutment shoulders etc. impair bearing performance and may lead to premature failure. The responsibility of such faults for bearing failure is not always easy to establish and much time can be lost in looking for the cause of failure.

## 2.6 Fits

Good bearing performance is largely dependent on adherence to the fits specified for the rings in the drawing (see table 7.3 and 7.4, pp. 86 to 100).

**Observe ring fits specified on drawing**

No one can give a straight answer to the question of the "right" fit; indeed the selection of fits is determined by the operating conditions of the machine and the design characteristics of the bearing assembly. Basically, both rings should be well supported over their seating areas and should therefore be tight fits. This is, however, not always possible, since it makes mounting and dismantling more difficult and is unfeasible with applications calling for easy axial displacement of one ring, for instance with floating bearings.

The interference produced by tight fits expands the inner ring and contracts the outer ring resulting in a reduction of radial clearance. Therefore, the radial clearance should be adapted to the fits.

The shaft and housing tolerances should be checked. Too loose a fit causes the ring to creep on the shaft which tends to damage both ring and shaft. It also affects the working accuracy of the machine or causes premature raceway fatigue from poor support. On the other hand, too tight a fit may result in detrimental preload and hot running of the bearing.

**Check shaft and housing tolerances**

As the walls of rolling bearing rings are relatively thin, possible poor geometry of the mating parts is transmitted to the raceways. The seats must therefore be checked for diameter and form tolerances. For cylindrical seats, cylindricity is checked (DIN ISO 1101). For tapered seats, roundness (DIN ISO 1101), taper angle and straightness (DIN 7178) are checked.

**Check form tolerance of shaft and housing seats**

The seating surfaces of shaft and housing smoothen, when joined, the bearing surfaces usually to a lesser degree. The rougher the surfaces, the more marked is the loss in interference. Therefore, the roughness of the bearing seats (DIN 4768) is also checked.

**Check roughness of bearing seats**

# Preparations

## 2.7 Inspection of Bearing Seats

For all measurements ensure that the measuring instrument has approximately the same temperature as the parts to be measured.

### 2.7.1 Cylindrical Seats

Shafts are generally checked with external micrometers (Fig. 2); The measuring accuracy must be checked by calibration.

2: External micrometer for measuring shaft diameters



3: A snap gauge ensures safe positioning and perfect measurement of cylindrical seats. The diameter for setting the gauge is marked on the master ring.



Another useful instrument is the snap gauge shown in fig. 3. It functions as a comparator and its correct setting is checked with master rings. These master rings are supplied by FAG for each diameter.

Bores are checked with internal micrometers (Fig. 4).

Conventional comparative measuring instruments are also used (Figs. 5 to 7).



4: Internal micrometer for bore measurements



5: Comparative measuring instruments are especially suitable for bore measurements. The master ring is used for setting.

# Preparations

6: A housing bore is measured with a bore measuring instrument.



7: Principle of the measurement with a bore measuring instrument (determination of the minimum dimension).

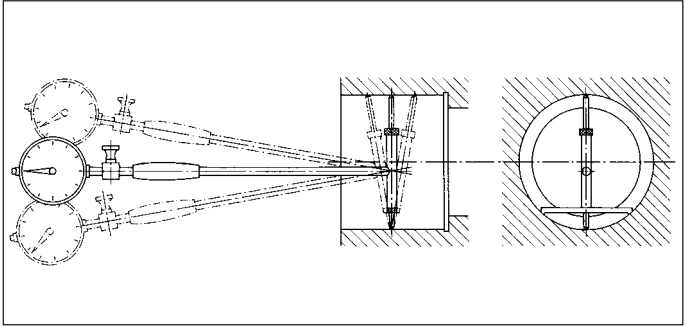

## Check diameter and cylindricity of shaft and housing seats

Shaft and housing seats are checked for their diameter and their cylindricity.

Normally, the diameter is measured in two different cross sections and several planes (two-point measurement) (Figs. 8 and 9).

8, 9: Usually the cylindricity of shaft and housing seats is checked by measuring the diameter in two cross sections and several planes (two-point measurement).

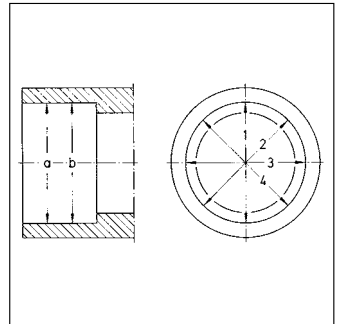
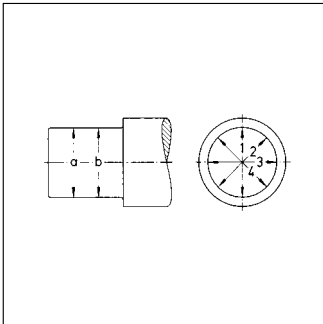

Unless otherwise specified in the shop drawing, the cylindricity tolerance should not exceed half the diameter tolerance (two-point measurement).

According to DIN ISO 1101, the cylindricity tolerance refers to the radius. The tolerance values specified according to this standard must therefore be doubled for two-point measurements.

## 2.7.2 Tapered Seats

Full inner ring support on the shaft requires exact coincidence of shaft taper and inner ring bore taper.

The taper of rolling bearing rings is standardized. For most bearing series it is 1:12, for some large width series 1:30.

The master taper ring (Fig. 10) is the simplest measuring device.

Conformity of shaft and master taper is ascertained by blueing. An inadequate shaft taper must be improved, until the master ring shows full width support. FAG supply master tapers for taper diameters from 25 to 150 mm.

Bearing inner rings should not be used as master rings.

For the exact checking of tapered shaft seats FAG developed the taper measuring instruments MGK 133 and MGK 132. The use of a reference taper or segment enables exact measurement of the bearing seat taper and diameter. Both instruments are easy to handle; the workpiece to be measured need not be removed from the machine.

**Do not use bearing inner rings as master taper rings**  
**Use FAG taper measuring instruments MGK 133 and MGK 132 for exact checking**



10: Master taper ring for checking small tapered bearing seats

# Preparations

11: Taper measuring instrument FAG MGK 133 for tapers with outside diameters of 27 to 205 mm and lengths of less than 80 mm



The taper measuring instrument FAG MGK 133 is provided for tapers of less than 80 mm length (Fig. 11).

## Measuring Ranges

Taper measuring instrument	MGK 133A	MGK 133B	MGK 133C	MGK 133D	MGK 133E	MGK 133F	MGK 133G
Taper dia. [mm]	27...47	47...67	67...87	87...115	115...145	145...175	175...205
Taper	Taper 1:12 and 1:30 (other angles on request)						
Min. taper length [mm]	17	21	28	34	42	52	65
Dist. betw. meas. planes [mm]	12	15	20	25	33	45	58

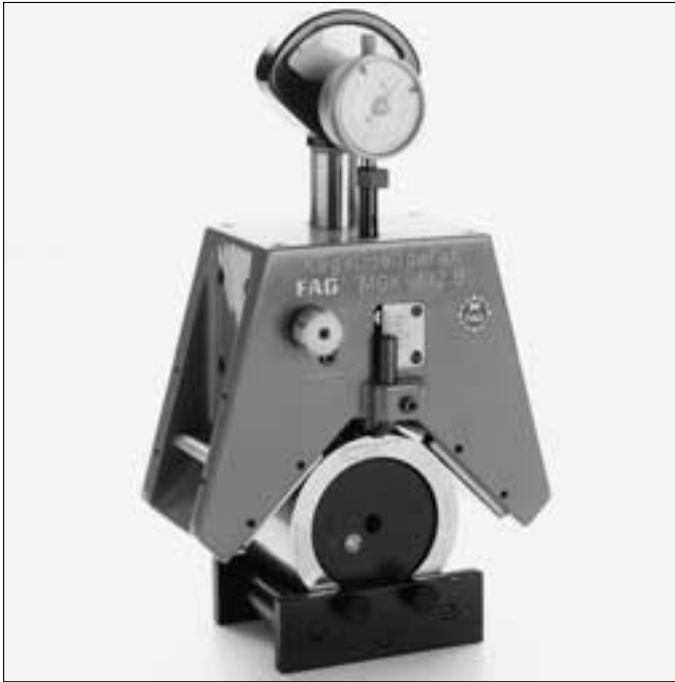

12: Taper measuring instrument FAG MGK 132 for tapers with outside diameters of 90 to 820 mm and lengths of more than 80 mm

The taper measuring instrument FAG MGK 132 is used for tapers of a minimum length of 80 mm and a minimum diameter of 90 mm (Fig. 12).

### Measuring Ranges

Taper measuring instrument	MGK 132B	MGK 132C	MGK 132D	MGK 132E
Taper dia. [mm]	90...210	190...310	290...410	390...510
Taper	Taper 1:12 and 1:30 (other angles on request)			
Min. taper length [mm]	80	80	110	125
Dist. betw. meas. planes [mm]	20	20	25	30

# 3. Rolling Bearing Mounting

The various bearing types and sizes require different mounting methods. Depending on the individual conditions these can be mechanical, hydraulic or thermal.

**Do not subject bearing rings to hammer blows**

**For non-separable bearings apply mounting force directly to the ring to be mounted**

As the hardened bearing rings are sensitive to blows, these must never be applied directly to the rings.

On mounting of non-separable bearings (Fig. 13), the mounting forces must always be applied to the ring which will have the tight fit and therefore is the first to be mounted. Forces applied to the ring with the loose fit would be transmitted by the rolling elements, thus damaging raceways and rolling elements.

Mounting of separable bearings (Fig. 14) is easier, since the two rings can be mounted separately. In order to avoid score marks during assembly, slightly rotate the parts.

13: If a tight fit is required for the inner ring of a non-separable bearing, the bearing will first be mounted on the shaft; then the shaft and bearing assembly is pushed into the housing.

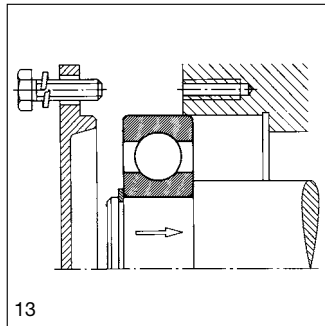

14: With separable bearings the rings can be mounted independently. This is especially advantageous when both rings get a tight fit. In order to avoid score marks, slightly rotate the parts when installing inner ring and shaft into outer ring and housing.

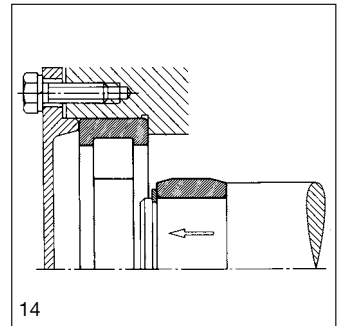

## 3.1 Mechanical Methods

### 3.1.1 Mounting of Cylindrical Bore Bearings

Bearings with a maximum bore of approximately 80 mm can be mounted cold. The use of a mechanical or hydraulic press is recommended (Fig. 15).

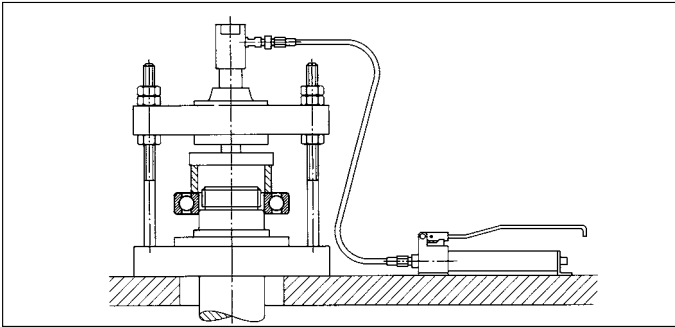

15: Bearings with a max. bore of 80 mm can be mounted on the shaft with a hydraulic press.

If no press is available, the bearing can be driven on the shaft by gentle taps with a hammer or mallet. However, a mounting sleeve with a flat face must be used in order to distribute the mounting force evenly over the entire ring circumference and to avoid damage to the bearing (Fig. 16).

The FAG mounting tool sets EINBAU.SET.ALU and EINBAU.SET.ST with perfectly matched precision components are suitable for correct mounting, see TI No. WL 80-49.

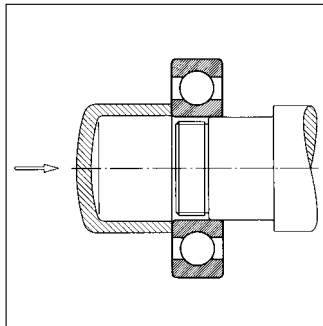

16: If necessary, small bearings can be driven on the shaft with gentle hammer taps, using an appropriate mounting sleeve.

The inside diameter of the sleeve should just be little larger than the bearing bore and, to avoid damage to the cage, its outside diameter should not exceed the inner ring shoulder height.

If a self-aligning bearing has to be pressed on the shaft and pushed into the housing at the same time, a disk should be used which bears against both bearing rings, thus avoiding misalignment of the outer ring in the housing (Fig. 17).

# Mounting

17: Simultaneous shaft and housing assembly of a bearing with the aid of a mounting disk.

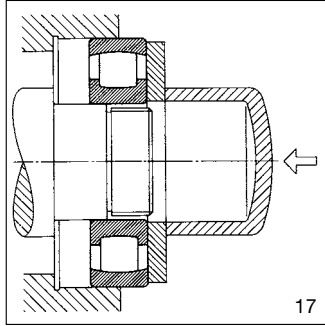

18: For some self-aligning ball bearings, the mounting disk must be relieved.

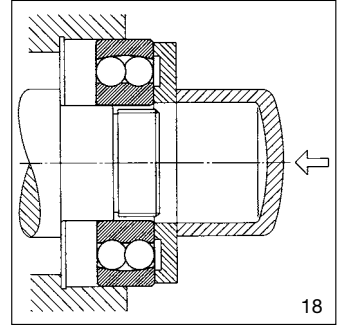

In some self-aligning ball bearings, the balls protrude beyond the rings. In such cases, the disk must be relieved (Fig. 18).

**Heat also small bearings to achieve heavy interference fits**

If very tight fits are required, even small bearings should be heated for mounting, chapter 3.2.

With light metal housings the seating areas might be damaged by press-fitting the outer ring in the housing bore. In such cases, the housing should be heated or the bearing cooled.

19: The outer rings of large cylindrical roller bearings are positioned by means of a mounting lever.

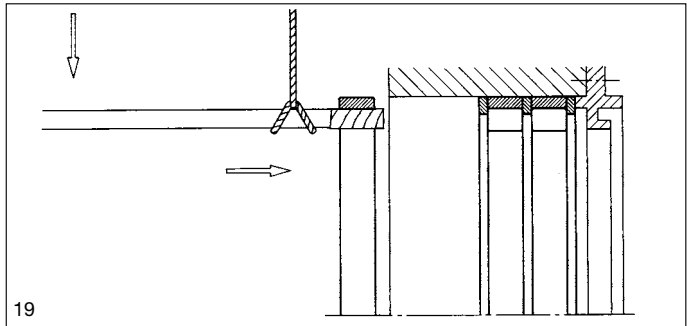

Heavy bearing outer rings with sliding fit can be mounted with a mounting lever (Fig. 19).

In order to avoid damage to the raceway and roller surfaces the end of the mounting lever should be wrapped with cloths (do not use cotton waste).

## Mounting of Needle Roller Bearings

### Needle Roller Bearings with Machined Rings

The same mounting principles apply to needle roller bearings as to cylindrical roller bearings. Bearings mounted in groups must have the same radial clearance to ensure uniform load distribution.

### Drawn Cup Needle Roller Bearings

Due to their thin outer rings the form accuracy for the drawn cup needle roller bearings is achieved by means of tight fits in the housing, making a lateral location unnecessary.

For mounting drawn cup needle roller bearings, special mounting mandrels are used. Usually the mandrel abuts the stamped bearing face which is hardened with smaller sizes. If the mounting mandrel is accurately dimensioned, it can be applied to an unhardened lip without deforming or jamming the needle roller and cage assembly (Figs. 20 and 21).

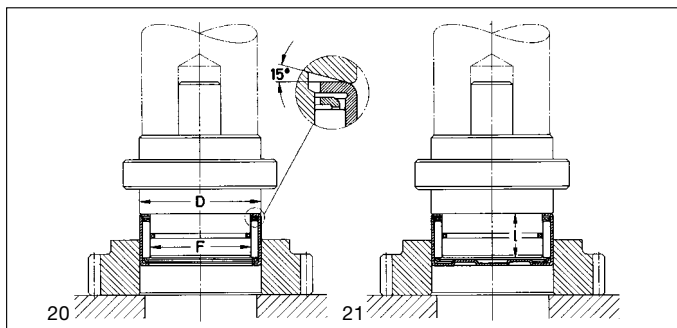

Drawn cup needle roller bearings are pressed into the housing with a mounting mandrel.

20: Drawn cup needle roller bearing, open ends

21: Drawn cup needle roller bearing, closed end

# Mounting

## Needle Roller and Cage Assemblies

Needle roller and cage assemblies are mounted between shaft and housing. In order to avoid score marks on the raceways and needle rollers, the needle roller and cage assemblies should be slightly turned and remain unloaded on mounting.

Needle roller and cage assemblies can be axially guided in the housing or on the shaft (Fig. 22).

The distance between the lateral cage guiding surfaces must be large enough (tolerance H11) to prevent the needle roller and cage assembly from jamming.

The radial clearance of needle roller and cage assemblies depends on the machining tolerances of the hardened and ground raceways on the shaft and in the housing. Needle roller and cage assemblies mounted in groups must be fitted with needle rollers of the same tolerance group.

22: Needle roller and cage assemblies can be guided in the housing or on the shaft.

a: Guidance in the housing

b: Guidance on the shaft

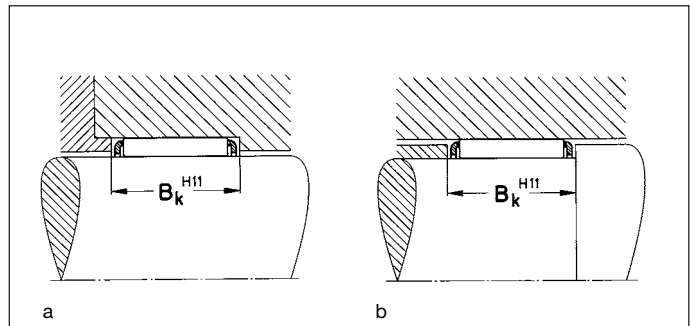

## Combined Needle Roller Bearings

The tight fits for the combined needle roller bearings require relatively high mounting forces. This must be borne in mind especially for needle roller-thrust ball bearings and needle roller-cylindrical roller thrust bearings with dust shield, where the ball or roller assembly of the thrust bearing is non-separable. It is advantageous to heat the housings for pressing-in these bearings.

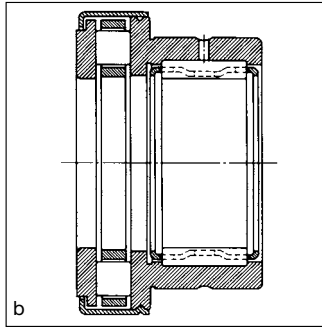
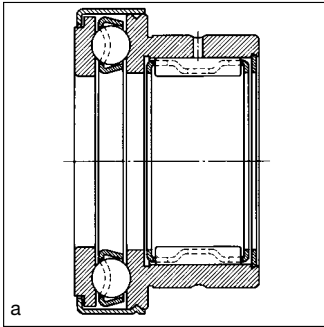

23: Combined needle roller - thrust ball bearings and needle roller - cylindrical roller thrust bearings with dust shield must be pressed into the housing.

a: Needle roller - thrust ball bearing

b: Needle roller - cylindrical roller thrust bearing

## Yoke Type Track Rollers

Since, in most cases, the inner ring of yoke type track rollers is subjected to point load, a tight fit on the shaft is not required. On mounting, ensure that the lubricating hole is located in the unloaded raceway zone. The outer ring of yoke type track rollers without axial guidance must be guided by lateral backing surfaces.

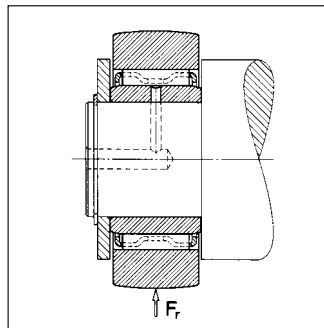

24: On mounting yoke type track rollers, the lubricating hole must be located in the unloaded zone of the raceway. The outer rings of yoke type track rollers without axial guidance must be guided by lateral backing surfaces.

## Stud Type Track Rollers

On mounting stud type track rollers, the radial lubricating hole should be located in the unloaded zone of the raceway.

On mounting a stud type track roller in the through-hole of a machine frame, the stud must usually be secured against rotating when tightening the nut. This is enabled by a slot at the flanged end of the stud (Fig. 25).

# Mounting

25: Rotation of the stud during tightening of a stud type track roller is prevented by the slot at the flanged end of the stud.

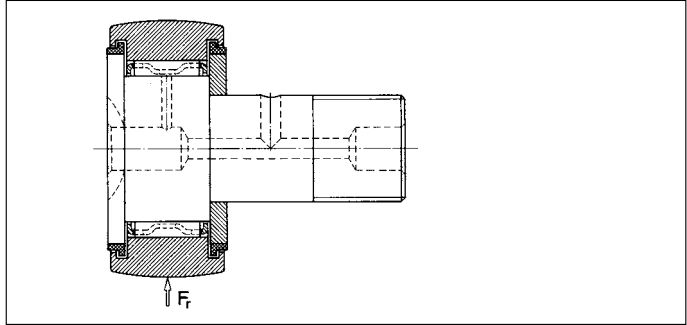

When a stud type track roller is screwed into a blind hole, the tightening torque must be applied through the slot. For this purpose, an appropriate tool is required (Fig. 26). About 75% of the tightening torques listed in the catalogues can be safely applied with these tools.

26: The stud of a stud type track roller can be screwed into a blind hole with special tools.

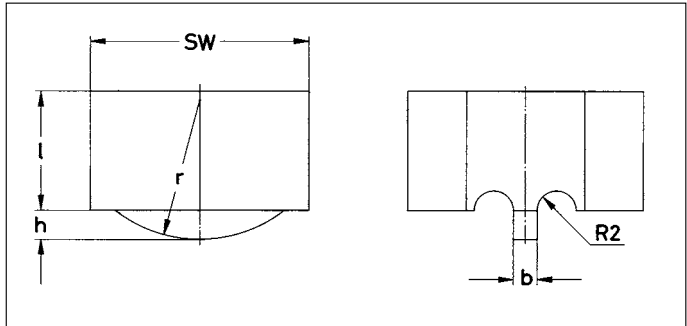

## 3.1.2 Mounting of Tapered Bore Bearings

Bearings with tapered bore are either fitted directly on the tapered shaft journal or, if the shaft is cylindrical, on an adapter sleeve or a withdrawal sleeve.

**Apply just a thin oil film to washed out bearing bore and seats on shaft and sleeve**

The oil film applied to the washed out bearing bore, shaft and sleeve should be very thin. A heavier coating would reduce friction and thus ease mounting; however, in operation the lubricant would be gradually forced out from the joint with a slackening effect on the tight fit, causing the ring or sleeve to creep and corrosion to develop on the surfaces.

Forcing the bearing onto the tapered seat expands the inner ring and reduces radial clearance. Therefore the reduction in radial clearance can be used as a measure of the seating condition of the inner ring.

The reduction in radial clearance is the difference between the radial clearance prior to mounting and the radial clearance after bearing mounting. It is necessary to determine the initial radial clearance before mounting and then to check the clearance repeatedly during mounting until the proper amount of reduction and thus the required tight fit are obtained.

Instead of measuring the reduction in radial clearance the distance the bearing is forced onto the tapered seat can be measured. For the standard inner ring bore taper of 1:12 the ratio of axial drive-up to radial clearance reduction is approximately 15:1. This ratio considers the fact that the expansion of the inner ring is more than 75 to 80% of the amount of interference existing between the fitted parts.

If, with small bearings, the exact axial drive-up cannot be measured, the bearing should be mounted outside the housing. The bearing should be driven up the tapered seat just enough to still turn smoothly and to allow the outer ring to be easily swivelled by hand. The serviceman must have a "touch" for the smooth running feature.

The radial clearance reduction, the axial drive-up distance or the expansion should also be measured, when a bearing is being refitted.

Special attention should be given to the locknut, the position of which may have changed due to the broaching effect in the seating areas and the settling of the threads. The values for the recommended reduction of radial clearance are listed in the appendix (tables 7.21 and 7.22, pp. 111 and 112).

The radial clearance is measured with feeler gauges (Fig. 27).

In case of spherical roller bearings, the clearance must be measured simultaneously over both rows of rollers (Fig. 28). Identity of clearance values, such as measured over both rows of rollers, ensures that there is no lateral offset of the inner ring relative to the outer ring. Aligning of the ring faces alone is, because of the width tolerances of the rings, no guarantee against such an offset position.

**Check radial clearance reduction, drive-up distance or expansion**

**Check radial clearance reduction, drive-up distance or expansion also during reassembly**

**Check radial clearance with feeler gauges**



27

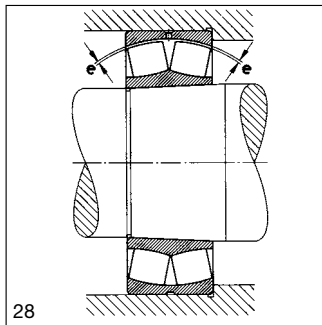

28

27: measuring radial clearance with feeler gauges before mounting

28: For spherical roller bearings, the radial clearance must be measured simultaneously over both rows of rollers.

# Mounting

## Check inner ring expansion of separable bearings

Cylindrical roller bearings offer the advantage of separate installation of inner and outer rings; the inner ring expansion can be measured - by means of an external micrometer - instead of the reduction of radial clearance (Fig. 29).

29: Measuring the expansion of a cylindrical roller bearing inner ring with an external micrometer



Mechanical and hydraulic equipment is available to pressfit the bearing on its tapered seat or to press a sleeve in place. Which method is the best to a given application depends on the mounting conditions.

## Mount small bearings with shaft nut and hook spanner

Press fit small and medium-size bearings with shaft nut on the tapered seat (Fig. 30). Tighten nut with hook spanner.

The adapter sleeve nut and hook spanner are used for driving small bearings onto the tapered seat of the sleeve (Fig. 31).

Shaft nuts are also used to press small withdrawal sleeves into the space between shaft and bearing inner ring (Fig. 32).

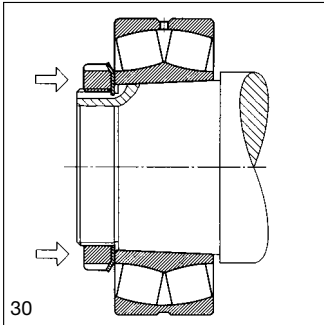

30: Press-fitting a spherical roller bearing with a shaft nut

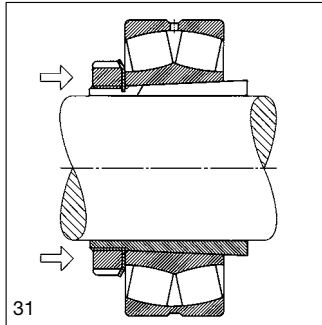

31: Press-fitting an adapter sleeve mounted spherical roller bearing with the adapter sleeve nut

## Double hook spanners

The double hook spanner sets FAG 173556 and 173557 are used for mounting self-aligning ball bearings onto adapter sleeves. Both sets include torque wrenches for more exactly determining the starting position before the bearing is driven onto the shaft.

On every double hook spanner there are rotation angles engraved for the self-aligning ball bearings that have to be mounted by means of these spanners so that the drive-up distance and radial clearance reduction can be adjusted accurately (Fig. 33).

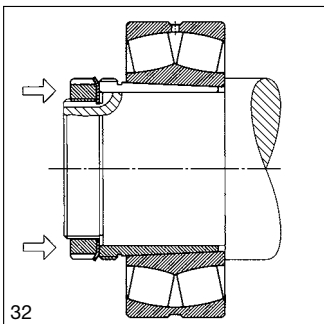

32: Press-fitting a withdrawal sleeve with the shaft nut

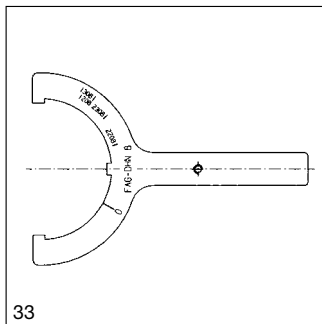

33: Double hook spanner with engraved rotation angles for fitting self-aligning ball bearings

# Mounting

34: Mounting nuts with thrust bolts facilitate mounting of large withdrawal sleeves. Between nut and sleeve a ring is inserted.

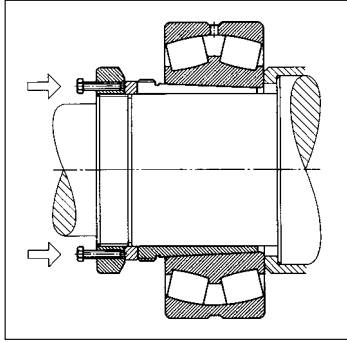

For larger bearings, considerable forces are required to tighten the nut. In such cases, the mounting nut with thrust bolts shown in Fig. 34 facilitates mounting.

To avoid tilting of the bearing or sleeve, the mounting nut should just be tightened enough to make nut and ring bear flush against their mating part. Then the thrust bolts of hardened steel, evenly spaced around the circumference of the nut, - their number depending on the forces required - are diagonally tightened, until the required reduction in radial clearance is obtained.

As the taper connection is self-locking, the mounting nut can then be removed and be replaced by the locknut. The procedure can also be applied to bearings mounted on an adapter sleeve or directly on the tapered journal.

**Use FAG hydraulic nuts for mounting of larger bearings**

When mounting larger bearings, it may be advisable to use a hydraulic press. Figs. 35 and 36 show how a spherical roller bearing is being press-fitted with the aid of a hydraulic nut <sup>1)</sup>. Hydraulic nuts are available for all regular sleeve and shaft threads. The hydraulic pro-

35: Hydraulic nut for mounting tapered bore bearings on a tapered shaft

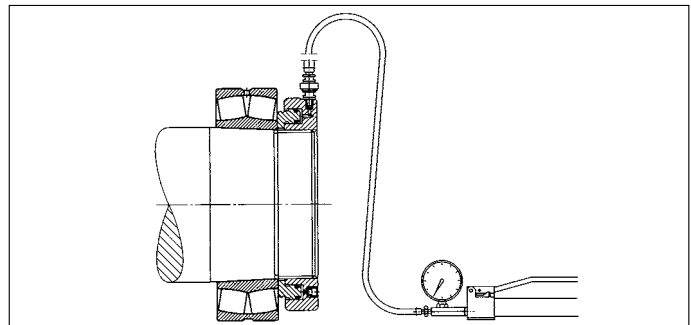

<sup>1)</sup> See „FAG Hydraulic Nuts“, Publ. No. WL 80 103 for nomenclature and dimensions.

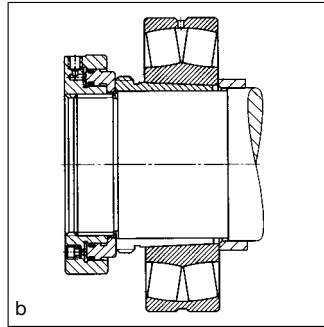
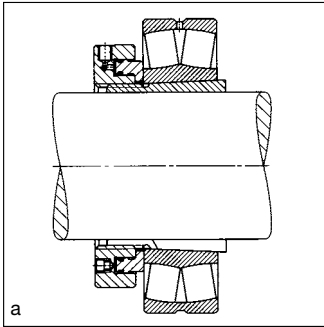

36: Mounting of a spherical roller bearing with an annular piston press.

a: Mounting on an adapter sleeve

b: Press fitting of a withdrawal sleeve

cedure described in chapters 3.3 and 4.3 is another valuable mounting and particularly dismantling aid.

## 3.2 Thermal Methods

If tight fits are specified for the inner rings on cylindrical shaft seats, the bearings are heated for mounting. Sufficient expansion is obtained when heated between 80 and 100°C. Accurate temperature control is essential in heating the bearings. If the temperature exceeds 120°C there is the risk of alteration of bearing grain structure resulting in a drop of hardness and dimensional instability.

For bearings with moulded cages of glass fibre reinforced polyamide the same temperature limits are valid as for the other rolling bearings.

Bearings with shields (Fig. 37a) and with seals (Fig. 37b) are packed with grease during manufacture. They can be heated up to 80°C maximum, but never in an oil bath.

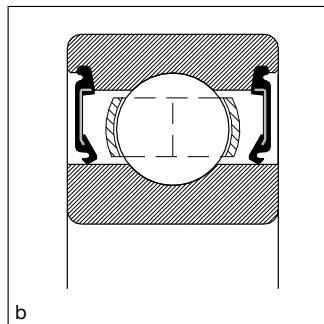
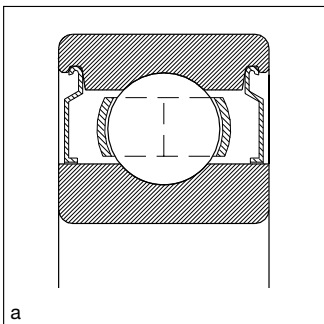

37: Never heat bearings with shields or seals in an oil bath. The maximum heating temperature is 80°C.

a: Bearing with shields

b: Bearing with seals

# Mounting

38: A ring is inserted between a heating plate without thermostatic control and the inner ring of an E spherical roller bearing with polyamide cage.

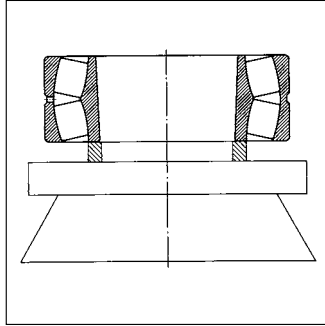

## 3.2.1 Heating Plate

Provisionally, rolling bearings can be heated on a heating plate which should be thermostatically controlled. Turn the bearing over several times in order to ensure uniform heating.

If the temperature of a heating plate without thermostatic control exceeds 120°C, polyamide cages must not contact the heating plate. This can be avoided by inserting a ring between the plate and the bearing inner ring (Fig. 38).

## 3.2.2 Oil Bath

For uniform heating, rolling bearings are generally immersed in an oil bath which is thermostatically controlled to a temperature of 80 to 100°C. The bearing should not be in direct contact with the heat source. The best arrangement is to have a screen several inches off the bottom of the oil tank which will prevent uneven heating of the bearing and protect it from contaminants settling on the tank bottom (Fig. 39).

The bearings may also be suspended in the oil bath (Fig. 40). After heating, any oil adhering to the bearing should be well drained off and the fitting surfaces should be carefully wiped clean.

39, 40: Heating in an oil bath ensures uniform heating of the bearings: A temperature of 80 to 100°C can be easily controlled. Disadvantage: Risk of contamination.

39: Heating a deep groove ball bearing in an oil bath

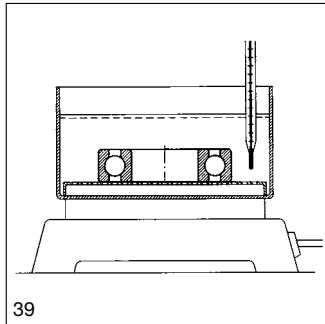

40: Heating cylindrical roller bearing inner rings in oil bath

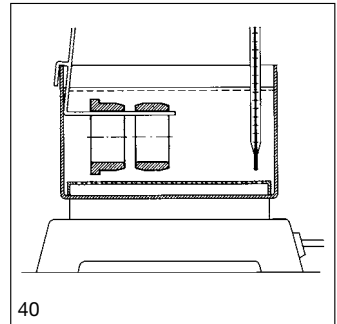

Mounting of heated rings or bearings requires some skill (Fig. 41). The parts should be rapidly pushed on the shaft and positioned squarely against the shoulder. A slight twisting motion during fitting facilitates the work. It is advisable to use heat-protective gloves or non-fraying cloths, but never cotton waste.

Larger bearings are generally transported with a crane. In this case the bearing is suspended in mounting grippers (Fig. 42) or in a rope sling. Working with the rope sling is not easy. Ensure alignment of ring and shaft in order to prevent tilting.

**Heat larger bearings for mounting**

**Do not use cotton waste in mounting work**



41: Heated bearing parts are rapidly pushed on the shaft and positioned squarely against the shoulder. This is facilitated by a slight twisting motion.

# Mounting

## 42: Mounting grippers

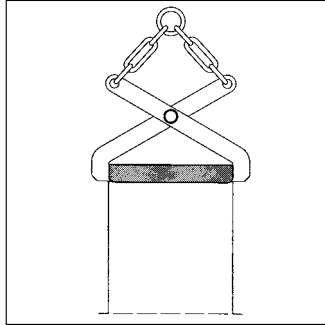

Provide for immediate axial location of mounted ring

When positioning, the inner ring should be immediately held tight against the shaft shoulder, until it has cooled down to avoid any clearance between ring face and shoulder after cooling. This also applies to a pair of rings mounted side by side.

### 3.2.3 Hot Air Cabinet

A safe and clean method of heating rolling bearings is by use of a hot air cabinet. Thermostat regulation enables accurate temperature control. Careful operation excludes contamination of the bearings. However, heating the bearings in hot air takes considerable time, therefore adequately dimensioned hot air cabinets should be provided for bath mounting.

### 3.2.4 Induction Heating Device

Rolling bearings are brought up to mounting temperature in a fast, secure and clean manner with induction heating devices, which operate on the transformer principle. The devices are used above all for batch mounting.

With the six FAG induction heating devices any rolling bearing types including greased and sealed bearings are heated. The smallest device AWG.MINI is used for bearings with 20 mm bores upwards. The maximum bearing mass is about 20 kg. The field of application of the largest device AWG40 starts at 85 mm bores. The maximum bearing mass may amount to approximately 800 kg.

See FAG TI No. WL 80-47 for description.



43,44: The induction heating devices ensure fast, clean and secure heating up to mounting temperature.

43: FAG AWG3,5



44: FAG AWG13

# Mounting

45: Induction coil for 380 V with bearing inner ring



## 3.2.5 Induction Coil\*)

Induction coils heat the inner rings of cylindrical roller and needle roller bearings of 100 mm bore onward.

The induction coils shown in this chapter can be used for both mounting and dismounting. They are, however, mainly used for ring withdrawal (chapter 4.2.2). Since heating for dismounting tight-fitted inner rings is very fast, the amount of heat transferred to the shaft is minimized so that the rings such as axle box roller bearings in rail vehicles, or for frequent dismounting and remounting of large-size bearings, as is the case for roll exchange in rolling mills.

FAG induction coils can be connected between two phases to the common three-phase current mains (50 or 60 Hz). For heating inner rings of a bore up to approximately 200 mm, coils are used which are connected directly to the 380 V mains (Fig. 45). For larger bearings the harmless low voltage equipment with 20 to 40 V at 50 Hz (60 Hz) should be used.

Low voltage induction coils are connected to the mains (380 V) via transformer (Fig. 46). The water-cooled winding provides for a better efficiency, easier handling and lower weight of the device.

\*) For details see Publ. No. WL 80107 EA "FAG Induction Heating Equipment".

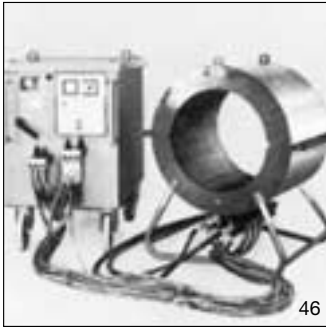

46



47

46: Low-voltage induction coil with transformer EFB 125/1, for cylindrical roller bearing inner rings of 635 mm bore  
Ring weight: 390 kg  
Approx. coil weight: 70 kg

47: Demagnetization of the inner ring of a cylindrical roller bearing by means of the induction coil

When the induction coils are used for mounting work, ensure that the rings are not overheated. The heatup times are indicated in the operating instructions.

The operating instructions also describe the use of the coil for demagnetization of the bearing rings upon completion of induction heating (Fig. 47).

**See operating instructions for heatup times**

### 3.2.6 Cooling

For a tight fit of the outer ring, the housing is heated in most cases to mounting temperature. With large and bulky housings, this may cause problems. In this case, the rolling bearing is cooled in a mixture of dry ice and alcohol. The temperature should not drop below  $-50^{\circ}\text{C}$ .

The condensation water resulting from temperature equalization must be completely rinsed out of the bearing with oil in order to prevent corrosion.

**Never cool bearings below  $-50^{\circ}\text{C}$**

# Mounting

48: Principle of hydraulic mounting; fluid film buildup between the mating surfaces.

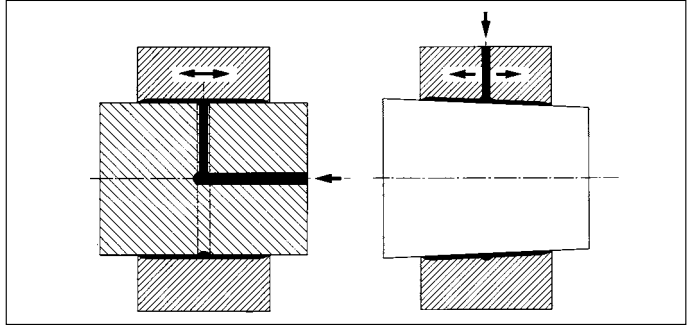

## 3.3 Hydraulic Method

With the hydraulic method, oil is injected between the mating surfaces. This may be machine oil, or oil containing rust dissolving additives. The oil film greatly reduces the friction between the mating parts which can then be easily displaced in relation to one another without the risk of surface damage. Fretting corrosion can be dissolved by means of kerosene or rust-dissolving additives to the oil.

Tapered bore bearings can be mounted on, and dismantled from, their tapered counterpart by the hydraulic method. Cylindrical bore bearings or sleeves are heated for mounting, whilst dismantling is performed hydraulically. For oil injection, oil grooves, feed channels and threaded connections for the pump are machined into shaft or the sleeve (Figs. 49, 50). See FAG publication WL 80 102 EA "How to Mount and Dismount Rolling Bearings Hydraulically" for technical details.

Hydraulic mounting of tapered bore bearings which are directly fitted on the tapered shaft end, requires but a small amount of oil. Simple, low feed injectors are therefore satisfactory (Fig. 51). FAG supply two sizes of oil injectors with connecting threads G 3/8 and G 3/4. The smaller oil injector is good for shaft diameters up to 80 mm, the larger for diameter up to 150 mm.

49: Position of the oil groove for a tapered bore bearing

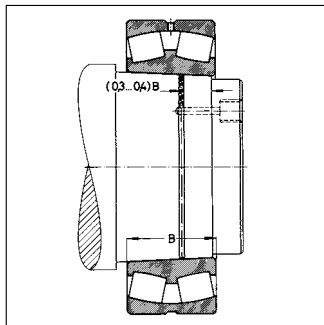

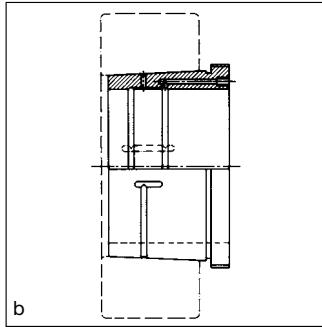
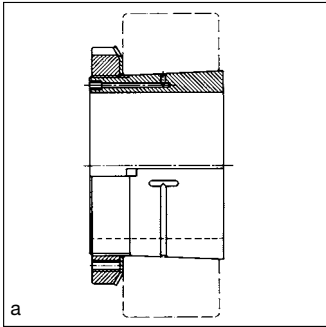

50: Larger adapter and withdrawal sleeves feature oil grooves and oil collecting grooves.

a: Adapter sleeve, design HG

b: Withdrawal sleeve, design H

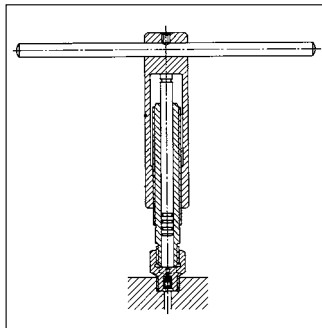

51: Oil injector and valve nipple for connecting thread G 3/8:

Oil injector: OILINJECTOR2500

Valve nipple:

OILINJECTOR2500.VALVE

for connecting thread G 3/4:

Oil injector: OILINJECTOR1600

Valve nipple:

OILINJECTOR1600.VALVE

It is different with cylindrical bore bearings and with adapter and withdrawal sleeves. Here, the oil loss occurring at the edges of the mating surfaces must be compensated by a higher rate of oil feed. This is achieved by an oil pump (Figs. 52 to 54), see FAG TI No. WL 80-50.

The fluid used is a machine oil of medium viscosity. Mounting work should be performed with an oil having a viscosity of about  $75 \text{ mm}^2/\text{s}$  at  $20^\circ\text{C}$  (nominal viscosity  $32 \text{ mm}^2/\text{s}$  at  $40^\circ\text{C}$ ).



52: FAG Hand pump set PUMP1000.4L, consisting of a two-step piston pump (1000 bar) with 4-litre oil container, manometer, 1 HP tube, plug-in joint (connecting thread G 1/4), metal box

# Mounting

53: FAG Hand pump set PUMP1600.4L, consisting of a two-step piston pump (1600 bar) with 4-litre oil container, manometer, 1 HP tube, plug-in joint (connecting thread G 1/4), metal box



54: FAG Hand pump set PUMP2500.8L.D, consisting of a two-step piston pump (2500 bar) with 8-litre oil container, two-way-valve, manometer, 2 HP tubes, 2 closing nipples G 1/4, 2 adapters and 6 reduction adapters, metal box



## Mounting of Tapered Bore Bearings

**Use shaft nut, thrust bolts or FAG hydraulic nut for mounting**

The bearing is pressed into position by a shaft nut, thrust bolts or the FAG hydraulic nut (see Fig. 35). Hydraulic withdrawal sleeves and adapter sleeves are provided with threaded oil bore connections M6, M8, G 1/8, G 1/4, depending on sleeve size (see FAG catalogue WL 41 520). The pumps shown in Figs. 52 to 54 feature an extreme pressure hose and are connected to the sleeve by reducing socket R, ERMETO tube E1 and steel pipe S (Fig. 55).

55: Hydraulic connection of a withdrawal sleeve

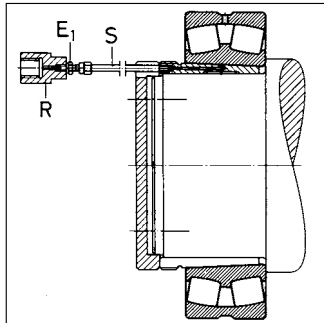



56: Mounting of a tapered bore spherical roller bearing by the hydraulic method

For mounting, oil is pumped between the mating surfaces. The axial forces required for mounting are applied through six or eight bolts located in the shaft nut or the adapter sleeve nut (Figs. 56 to 59).

A spacer between the bolts and the sleeve or bearing ring prevents damage to the latter. When pressing in a withdrawal sleeve as shown in Fig. 58, the pipe for the hydraulic fluid passes through the shaft nut. The amount of axial drive-up of the bearing or the withdrawal sleeve depends on the required reduction of radial clearance (tables 7.21 and 7.22, pages 111 and 112). The bearing must not, of course, be under oil pressure, when the radial clearance is being measured.

After relieving the oil pressure, the bearing is still kept under axial preload. Wait for 10 to 30 minutes, until oil has completely drained off from the fitting surfaces. As a final step, the mounting device (nut with thrust bolts or hydraulic nut) is removed and the shaft or sleeve nut put in place and locked.

**Relieve bearing of oil pressure prior to measuring radial clearance**

**Keep bearing under axial preload for 10 to 30 minutes after relief of the oil pressure**

# Mounting

57: Bearing seated on shaft: The oil is pumped between the mating surfaces; at the same time pressure from bolts or a nut drives the bearing up the tapered journal. The reduction in radial clearance or the axial drive-up distance is measured.

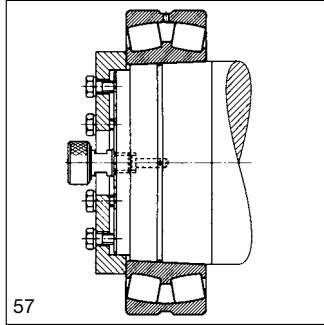

58: Bearing seated on withdrawal sleeve: The oil is pumped between the mating surfaces. The sleeve is pressed into the bearing bore with bolts and the reduction in radial clearance is measured.

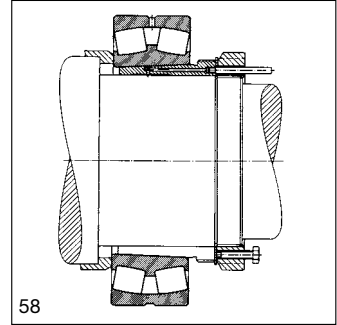

59: Bearing seated on adapter sleeve: The oil is pumped between the mating surfaces. Bolts drive the bearing up the sleeve and the radial clearance reduction is measured.

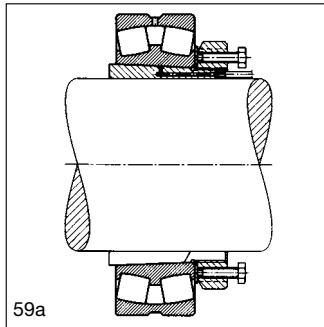

a: Oil bore in small end of sleeve

b: Oil bore in large end of sleeve

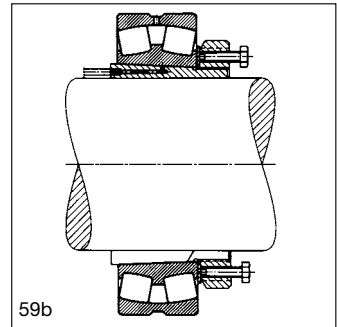

## 3.4 Clearance Adjustment on Mounting

### 3.4.1 Angular Contact Ball Bearings and Tapered Roller Bearings

Angular contact ball bearings and tapered roller bearings are always mounted in pairs. The axial and radial clearance of two bearings mounted in opposition is adjusted on mounting, the clearance or pre-load depending on the operating conditions. Angular contact ball bearings of universal design can be mounted in pairs or groups in any arrangement.

High loads and high speeds cause a temperature rise at the bearing location. This leads to thermal expansion and clearance variation. The type of clearance variation, i. e. an increase or a decrease, depends on arrangement and size of the bearings, the shaft and housing material and on bearing centre distance.

If close shaft guidance is required, the clearance is adjusted by stages. Each adjustment should be followed by a trial run and a temperature check. Thus, it is ensured that the clearance does not become too small, resulting in a higher running temperature.

A welcome effect of trial runs is that the whole bearing mounting "settles" and that, afterwards, the clearance practically remains stable (see also page 51).

The right temperature for a bearing, operating in the medium to high speed range under medium load, can, indicatively, be defined as follows: In the absence of extraneous heat, a correctly adjusted bearing is allowed to attain, during the trial runs, a temperature of about 60 to 70°C. After 2 or 3 hours running, this temperature should, however, drop, especially when in the case of grease lubrication, the churning action diminishes, after the excess grease is expelled from the bearing interior.

Bearings exposed to vibration at low speeds are mounted with zero clearance or even preloaded to avoid the risk of the balls or rollers brinnelling the raceways. Angular contact ball bearings and tapered roller bearings are adjusted against one another by nuts on the shaft (Fig. 60), by shims (Fig. 61) or threaded rings in the housing.

Axial clearance or preload of adjustable bearings is established by loosening or tightening the adjusting nut or by the insertion of calibrated shims. From the thread pitch, axial clearance and preload can be converted into turns of the adjusting nut.

**A high speeds, adjust axial clearance by stages**

**Provide for zero-clearance or preload of a bearing exposed to vibration at low speeds**

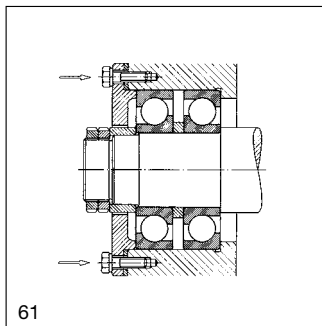
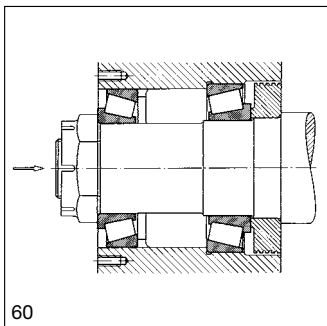

60: Adjustment of tapered roller bearings of a loose wheel with the shaft nut

61: Axial location of paired angular contact ball bearings; clearance adjustment with shim

# Mounting

The changeover from clearance to preload during adjustment is found by constant manual rotation of the shaft. Simultaneously, a dial gauge is applied to check the axial freedom of the shaft.

## Adjust with torque wrench

A simpler method for correct bearing adjustment is the use of a torque wrench. The adjusting nut is tightened to the appropriate torque (e. g. for passenger car front wheel bearings 30 or 50 Nm. The right torque is determined in tests; the values are specified in the repair instructions).

Loosening of the nut by approximately 1/12th of a turn provides for the required clearance. In tapered roller bearings, the rollers should bear against the cone back face rib during assembly. If the rollers were to contact the rib only after mounting is completed, i. e. when the bearing should therefore be alternatively turned in both directions during mounting.

In matched, multi row tapered roller bearings (Figs. 62 and 63), the axial clearance is a function of the spacer width. To determine distance "a" FAG developed the measuring devices of series MGS 155. Details are gladly supplied on request.

62: Matched tapered roller bearings in X arrangement (suffix N11CA)

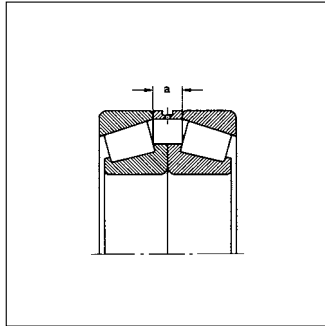

63: Double row tapered roller bearing in O arrangement

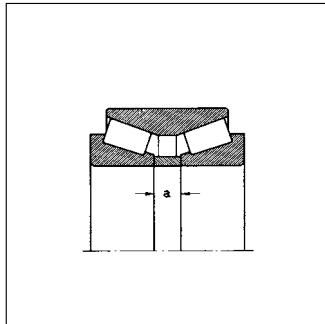

## Example:

Installation and adjustment of tapered roller bearings in the wheel hubs of motor vehicles (Fig. 64).

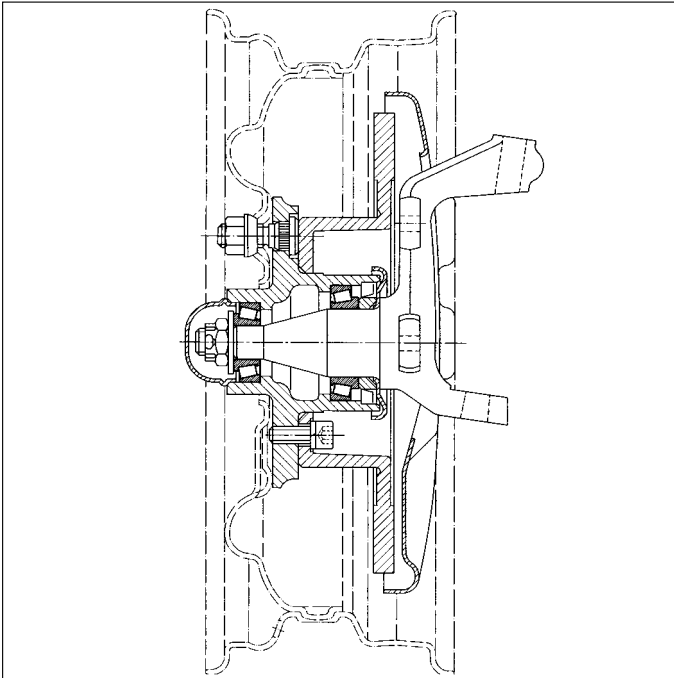

64: Passenger car front wheel with adjusted tapered roller bearings

# Mounting

## Proceed as follows:

1. Clean hub and carefully remove any chips and burrs.
2. Apply thin oil film to bearing seats. Press the two cups in place with a die. Make sure the die contacts only the cup face. Take care that the cup faces fit well against the hub shoulders (Fig. 65).
3. Grease cone of inner bearing.  
Pack grease also in the spaces between cage, cone, and rollers (Fig. 66).
4. Insert cone into hub.
5. Press shaft seal ring into hub with sealing lip pointing towards bearing.
6. Mount protective cap and spacer on the shaft. Make sure spacer face has full support against shaft shoulder (Fig. 67).
7. Mount hub on shaft; make sure seal is not damaged.

65: Fitting of the bearing cup with a die.

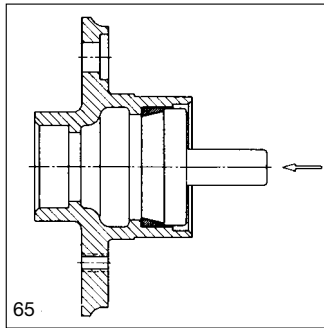

66: Pack roller/cage assembly of tapered roller bearing with grease

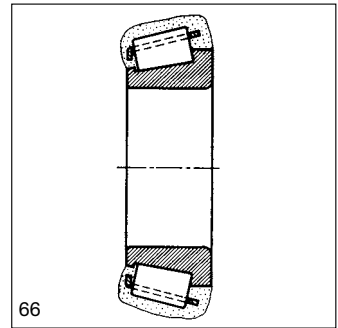

67: After the protective cap, the spacer is mounted on the shaft.

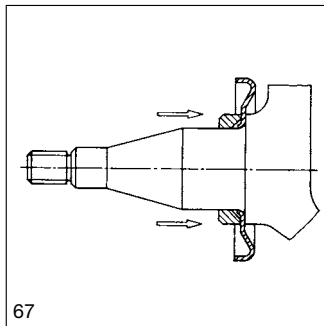

68: Tighten castle nut while rotating the wheel, until drag is felt. Back off castle nut by 1/12 turn at the most, until alignment with next cotter pin hole is obtained and fit cotter pin

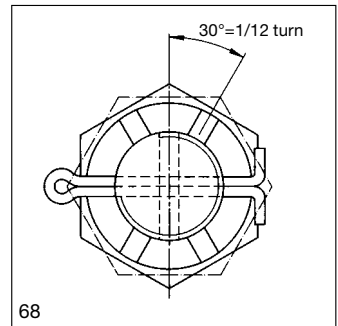

8. Apply grease well to cone of outside bearing and mount on shaft.
9. Mount safety plate.
10. Fit castle nut.
11. Tighten castle nut while the wheel is being rotated until drag is felt (use torque wrench, if possible; follow repair instructions).
12. Back off castle nut approximately 1/12 turn, until alignment with the next cotter pin hole is obtained and fit cotter pin (Fig. 68).
13. Check bearing for running smoothness and wobble. The wheel must not drag, but rotate freely. Be sure the wheel does not wobble. If necessary, change safety plate or nut. If the illustrated dial gauge (Fig. 69) is available, check axial clearance. 0 to 0.05 mm are optimum values.
14. Mount cover.
15. Perform test run to check for change of bearing clearance. Re-adjust, if necessary.

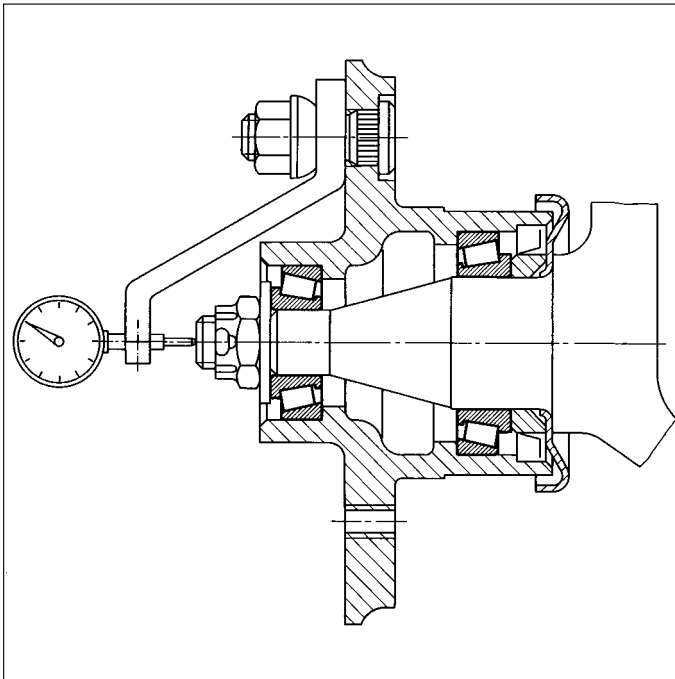

69: Measurement of axial clearance

# Mounting

70: Zero clearance double direction thrust ball bearing

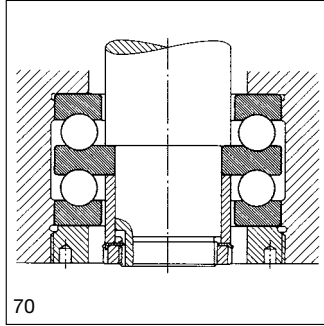

71: Cylindrical roller thrust bearing preloaded with shim S

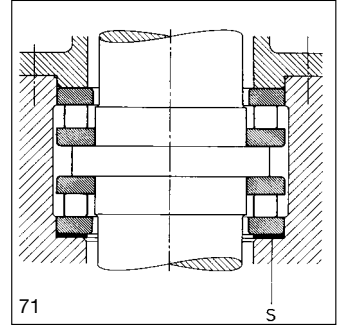

This is a field-proven method of adjusting wheel bearings requiring no special tools. There are other methods which, however, necessitate mounting tools and measuring instruments. They are primarily intended for batch mounting.

## 3.4.2 Thrust Bearings

With thrust bearings, the shaft washers are generally transition fits, tight fits being the exception. The housing washers are always loose fits. The shaft washer of double direction thrust bearings should always be positively locked axially (Fig. 70). The mounting and dismounting of thrust bearings offers no difficulties.

## 3.4.3 Machine Tool Bearings

For machine tool spindles, the correct adjustment of bearing clearance is of paramount importance because it controls the quality of the machined workpieces. For correct adjustment, on mounting, of the operating clearance or preload specified by the designer, FAG developed special measuring devices. These are used for today's widely employed spindle bearing arrangements with double row cylindrical roller bearings (Fig. 72). The correct preload of double direction angular contact thrust ball bearings is automatically adjusted during mounting.

The radial clearance of a mounted cylindrical roller bearing is equal to the difference between the boundary circle diameter of the rollers, and the raceway diameter of the lipless ring. For gauging the boundary circle, FAG supply the boundary circle measuring instruments MGI 21 and MGA 31.

The raceway diameter of cylindrical roller bearings NNU49SK is measured with a snap gauge, the raceway diameter of series NN30ASK with a plug gauge.

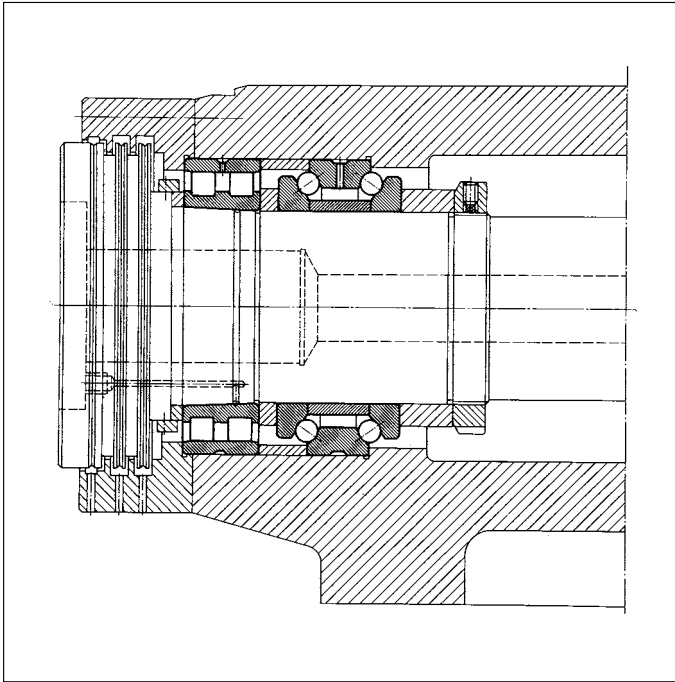

72: Bearing assembly of a fineboring spindle (work end). The radial clearance of the double row cylindrical roller bearing is adjusted on mounting.

FAG boundary circle measuring instruments are comparators allowing to measure the radial clearance within a measuring accuracy of  $\pm 1$  micron.

For precise adjustment of the radial clearance, the form accuracy of the bearing seats, i. e. their roundness, cylindricity or taper, is important (also see p. 12 "Inspection of bearing seats").

### **Boundary Circle Measuring Instrument MGI 21**

The radial clearance or preload of cylindrical roller bearings with separable inner ring (NNU49SK) is the difference between the diameter of the circle under the rollers  $H_1$  and the raceway diameter  $F$ . The circle under the rollers is the circle which contacts all rollers from inside, when they are in contact with the outer ring raceway (Fig. 73).

The circle under the rollers is measured with the aid of the instrument MGI21; the radial clearance of the mounted bearing can be determined together with a snap gauge (Fig. 74).

The two opposed steel segments of the boundary circle measuring instrument form the measuring surfaces. The lower segment is stationary, the upper can be displaced; the movement being read from the dial gauge.

# Mounting

73: Diameter under rollers  $H_i$  of cylindrical roller bearings NNU49SK (separable inner ring)

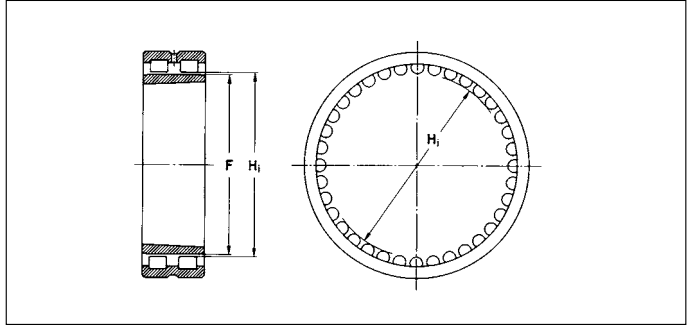

After having determined the boundary circle of the mounted outer ring roller assembly, this value is transmitted to the snap gauge. During inner ring mounting on the tapered shaft seat, the expansion of its raceway diameter is constantly checked with the aid of the snap gauge. Positive values on the dial gauge indicate preload, negative values indicate radial clearance; a zero value indicates a clearance-free bearing.

74: The measured diameter under rollers is transmitted to the dial indicator snap gauge. The boundary circle measuring instrument FAG MGI 21 is used for cylindrical roller bearings with separable inner ring, such as FAG NNU49SK.



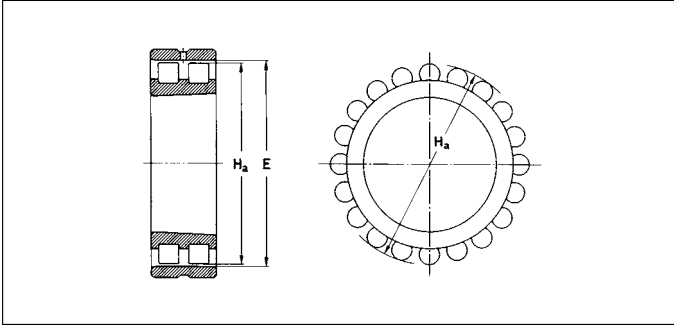

75: Diameter over rollers  $H_a$  of cylindrical roller bearings NN30ASK (separable outer ring)

## Boundary Circle Measuring Instrument MGA 31

The radial clearance or preload of cylindrical roller bearings with separable outer ring (NN30ASK) is the difference between the diameters of the raceway  $E$  and the circle over the rollers  $H_a$ . The circle over the rollers is the circle which circumscribes all rollers when they are in contact with the inner ring raceway (Fig. 75).



76: The measured raceway diameter is transmitted to the boundary circle measuring instrument with the aid of an internal dial gauge. The boundary circle measuring instrument FAG MGA 31 is used for cylindrical roller bearings with separable outer ring, such as FAG NN30ASK.

# Mounting

The circle over the rollers is measured with the instrument MGA 31; the radial clearance of the mounted bearing can thus be determined together with an internal dial gauge (Fig. 76).

The two opposed steel segments of the boundary circle measuring instrument form the measuring surfaces. One segment is stationary; the other can be displaced. The movement can be read from the dial gauge.

During measuring, the bearing outer ring has to be mounted in the housing. After having determined the outer ring raceway diameter with the aid of an internal dial gauge, this value is transmitted to the boundary circle measuring instrument.

During mounting, the inner ring with cage and roller assembly is pushed onto the tapered shaft seat until positive contact is established. The boundary circle measuring instrument is applied and the inner ring driven onto the taper seat, until the dial gauge indicates the required value.

Positive values indicate preload, negative values indicate radial clearance; a zero value indicates a clearance-free bearing.

## The Steady-State Temperature as a Means of Clearance Control

In the case of high-speed spindles, the operating clearance or preload can be verified from the bearing temperature registered during trial runs.

For temperature control, the bearing housing must be provided with bores for the insertion of temperature sensors (Fig. 77). These bores should be drilled prior to bearing installation. To obtain the true bearing temperature, the sensors must be in direct contact with the bearing rings. Controlling merely the temperature of the cylindrical roller bearing will not do; the temperature of the preloaded angular contact thrust ball bearing should also be measured.

Sensors should contact bearing rings

77: Arrangement of heat sensors

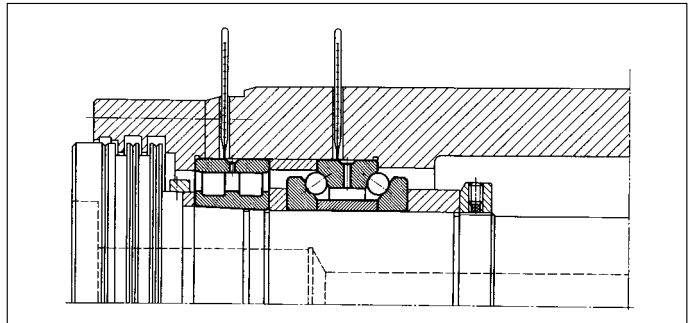

# 4. Rolling Bearing Dismounting

The trial run should be long enough to allow the operating temperature to come to a steady state; this will happen after half an hour to three hours depending on machine size. Steady-state temperatures from 50 to 60°C are acceptable, when the spindle operates at its top speed; experience has shown that at this temperature bearing clearance is optimum.

## 4. Rolling Bearing Dismounting

If the bearings are intended for re-use, dismounting must be performed most carefully; it is imperative that the extracting tool be applied to the ring to be extracted to prevent the rolling elements from brinelling the raceways (Fig. 78a). In addition, thin-walled outer rings involve the risk of ring fracture (Fig. 78b).

With non-seperable bearings, first withdraw the ring with sliding fit from its seat and then dismount the tight-fitted ring. The force required for dismounting is generally higher than the mounting force, since, as time passes, the ring becomes embedded on its seat. Even with loose-fitted rings, fretting corrosion may make dismounting work difficult.

Apply tool to the ring to be extracted

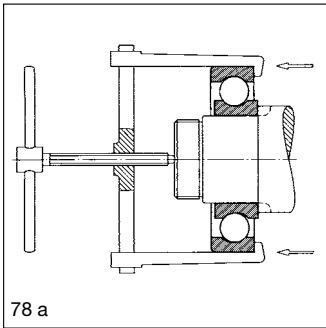

78 a

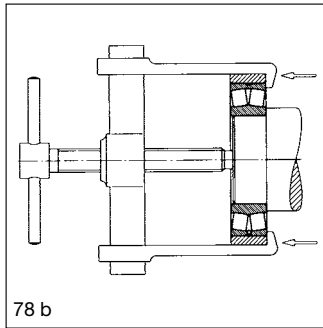

78 b

78a: Wrong! Do not apply dismounting force through the rolling elements, if you want to re-use the bearing.

78b: If dismounting through the rolling elements is unavoidable, put a collar of unhardened steel round the outer ring (thickness 1/4 greater than bearing cross section height). This applies especially to bearings with small cross section height and small contact angle (such as tapered roller and spherical roller bearings). The bearings shall not be reused.

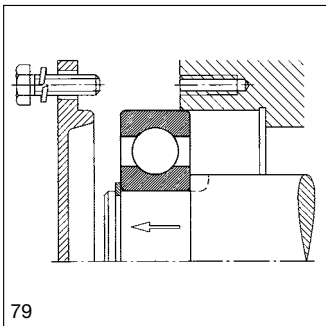

79

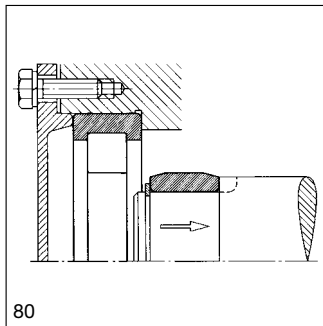

80

79: Start dismounting of nonseparable bearings with the loose-fitted ring.

80: The ring of separable bearings can be dismounted separately.

# Dismounting

## 4.1 Mechanical Methods

### 4.1.1 Dismounting of Cylindrical Bore Bearings

Small bearings are usually dismounted with the aid of mechanical extracting devices (Figs. 81, 82) or hydraulic presses (Fig. 83). These are applied either directly to the tight-fitted ring or to the mating parts, such as the labyrinth ring.

81: Dismounting of a barrel roller bearing with an extractor



82: Extracting devices for rolling bearings

a: Extractor with puller arms for split ring

b: Extractor with three adjustable arms

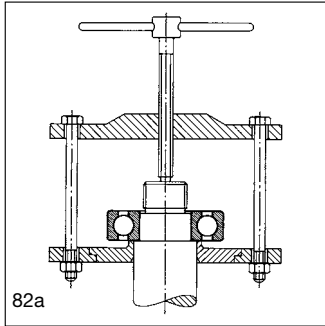

82a

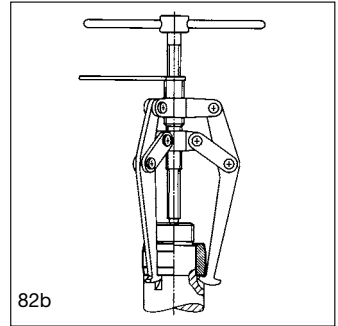

82b

83: Dismounting is facilitated by use of a press.

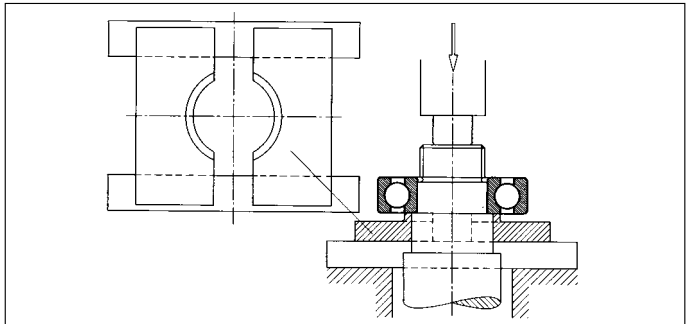

Provisionally, small bearings can be driven off their seat with a hammer and a metal drift (Fig. 84, right). The light hammer blows should be applied evenly round the whole circumference of the tight-fitted ring.

Dismounting is greatly facilitated, if extracting slots are provided so that the extractor can be directly applied to the tight-fitted bearing ring (Figs. 85, 86 and 87).

**Provide extracting slots**



84: Provisional bearing dismounting by hammering  
left: wrong  
right: correct  
(use soft metal drift)

**Do not subject the bearing rings to hammer blows**

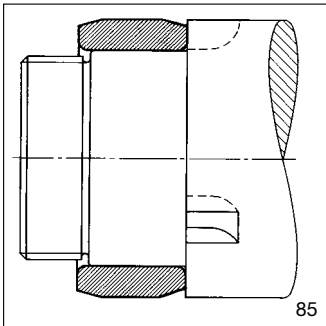

85

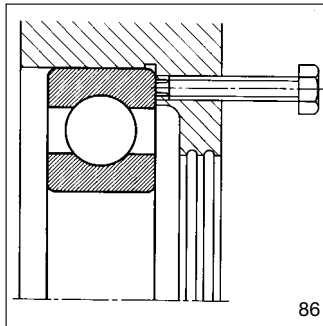

86

85: Slots in the shaft shoulder to apply bearing extractor

86: Bores for extraction nuts

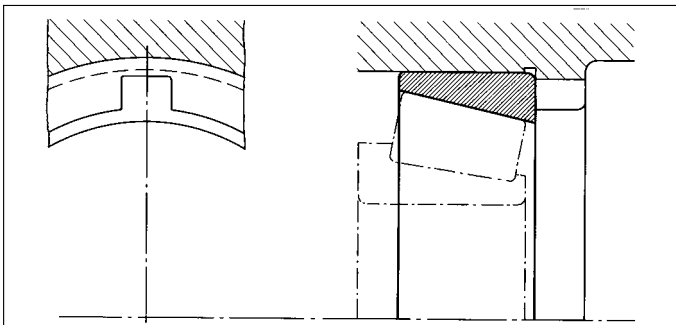

87: Slots for bearing outer ring removal

# Dismounting

When the inner ring abuts the shaft shoulder and when no extracting slots are provided, ball bearings, tapered roller bearings and cylindrical roller bearings can be dismantled with a special extractor. With the ball bearing extractor (Figs. 88, 89c), the clamping piece inserted in the extractor engages with finger-shaped extensions between the balls at the inner ring raceway edge; with extractors for cylindrical and tapered roller bearings the clamping piece engages behind the rollers (Fig. 89a).

88: Ball bearing extractor with clamping piece



89a: Collet for tapered roller bearings and cylindrical roller bearings with separable outer rings/cups

89b: Collet for tapered roller bearings and N-type cylindrical roller bearings with unseparable outer rings (cups).

89c: Collet for deep groove ball bearings



The clamping piece forms part of a collet and is clamped against the inner ring with a tapered clamping ring. The extraction force is generated by a spindle. This extractor enables bearings mounted in the housing to be withdrawn from the shaft.

Mechanical FAG extractors see TI No. WL 80-48.

## 4.1.2 Dismounting of Tapered Bore Bearings

### 4.1.2.1 Dismounting of Adapter Sleeve Mounted Bearings

For dismounting bearings directly seated on the tapered shaft or an adapter sleeve, loosen the locking device of the shaft or sleeve nut. Loosen nut by an amount corresponding to the drive-up distance. Drive inner ring off the adapter sleeve or tapered shaft seat by gentle hammer taps, using a soft metal drift (Fig. 90) or, even better, a piece of tubing (Fig. 91).

When a press is used, support the adapter sleeve or the loosened adapter sleeve nut and withdraw the bearing from the sleeve.

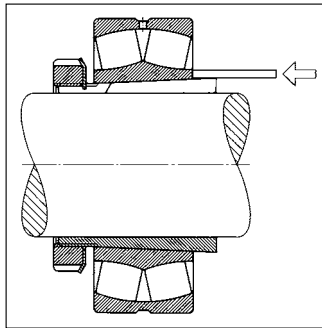

90: Dismounting of a small, adapter sleeve mounted spherical roller bearing. The inner ring is driven off the sleeve by means of a metal drift.

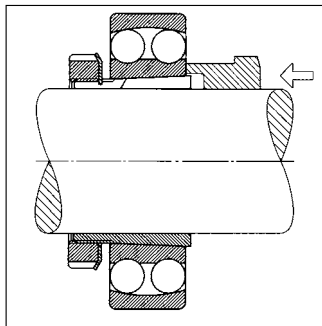

91: Dismounting of an adapter sleeve mounted self-aligning ball bearing. The use of a piece of tubing prevents damage to the bearing.

# Dismounting

92: Hydraulic nut for dismounting an adapter sleeve mounted spherical roller bearing

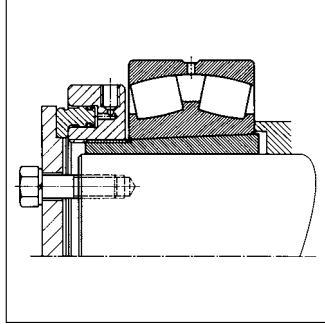

Adapter sleeves can be released with a hydraulic nut provided the bearing rests against an angular support ring. The nut should take support on a plate or the like (Fig. 92).

## 4.1.2.2 Dismounting of Withdrawal Sleeve Mounted Bearings

Withdrawal sleeve mounted bearings are removed by means of the extraction nut (Fig. 93a). For this purpose, the shaft must be removed. In difficult cases (for large-size bearings), extraction nuts with additional thrust bolts can be used (Fig. 93b). A washer is inserted between inner ring and thrust bolts.

Dismounting of withdrawal sleeves is much easier and less costly with hydraulic nuts (Fig. 94). Withdrawal sleeves projecting beyond the shaft end, should be backed up by a thick-walled support ring.

93: Dismounting of a withdrawal sleeve

a: with extraction nut

b: with nut and thrust bolts applied to the inner ring through a washer

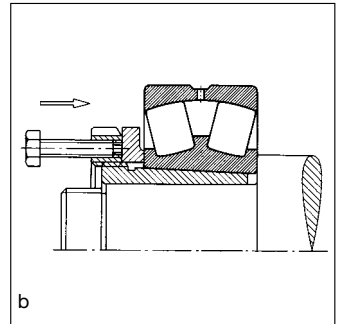
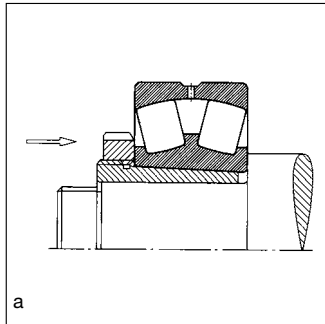

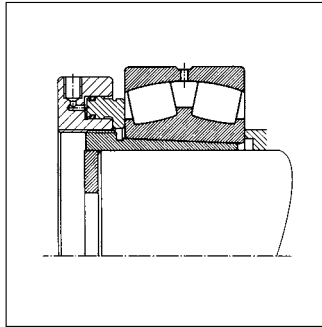

94: Hydraulic nut for dismounting a withdrawal sleeve mounted spherical roller bearing. The projecting portion of the sleeve is backed up by a thick-walled support ring.

## 4.2 Thermal Methods

### 4.2.1 Heating Ring \*)

Heating rings are used for dismounting cylindrical roller bearing and needle roller bearing inner rings without lip or with one lip only. The heating rings of light alloy are radially slotted. Their insulated handles provide for easy handling (Fig. 95).

With an electric heating plate, the heating rings are heated to a temperature of 200 to 300 °C, placed around the inner ring to be extracted and clamped by means of the handles. The heat is rapidly transferred from the heating ring to the inner ring. When the tight inner ring fit on the shaft is loosened, withdraw both rings simultaneously. After extraction, remove the inner ring immediately from the heating ring to avoid overheating. Heating rings are of great advantage for occasional withdrawal of small or medium-size bearing rings, each bearing size requiring its own heating ring.

\*) For details see TI No. WL 80-9 „FAG Aluminium Heating Ring“.



95: Heating rings are used for dismounting cylindrical roller and needle roller bearing inner rings.

# Dismounting

## 4.2.2 Induction Coil\*)

Induction coils (also see chapter 3.2.5) are used for withdrawing shrunk-on cylindrical roller and needle roller bearing inner rings of 100 mm bore onward from the shaft. Since the coil heats up at a very fast rate, the amount of heat transferred to the shaft is minimized so that the rings can be easily withdrawn.

Induction coils can be connected between two phases to the common three-phase mains (50 Hz or 60 Hz). For dismounting rolling bearings with a maximum bore of 200 mm, coils are used which are connected directly to the 380 V mains. For larger bearings, the harmless low voltage equipment - 20 to 40 V/50 Hz (60 Hz) - should be used.

Low voltage induction coils are connected to the mains (380 V) via a transformer (Fig. 96). The water-cooled winding provides for a better efficiency, easier handling and lower weight of the coil.

For extraction, the induction coil is pushed over the inner ring and the fingers provided on the coil grip the ring at its back face. The labyrinth ring features milled recesses to allow positioning of the fingers. The current is switched on and, as soon as the ring is heated to 80 to 100°C, the current is disconnected and the ring together with the appliance removed from the shaft.

\*) For details see publ. no. WL 80107 EA "FAG Induction Heating Equipment".

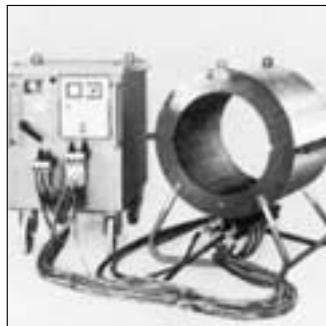

96: Low-voltage induction coil with transformer EFB 125/1, for cylindrical roller bearing inner rings of 635 mm bore:  
Ring weight                    390 kg  
Approx. coil weight         70 kg

## 4.2.3 Ring Burner

If no oil grooves are provided in the shaft for hydraulic mounting, and if electric devices are not economical, inner rings of larger separable bearings can also be dismounted by heating them with a flame.

Never should a welding torch be used because of the danger of overheating or unequal heating of the ring. The uniform, high hardness and dimensional stability of the bearing ring could be affected.

Ring burners (fig. 97) have proven to be an acceptable solution. The burner should clear the ring surface by 40 to 50 mm. At the usual gas pressure, the diameter of the burner jet is 2 mm. Flame temperature and flame length are adjusted by the addition of air. The burner jets should be bored in staggered arrangement and be spaced 20 to 45 mm apart. For small rings and heavy interference fits, the burner should be operated for maximum heat output. Air should only be added after burner ignition. There must be provisions for the air pressure to be delicately adjustable, since excessive pressure may force the gas back into the mains.

Use ring burner

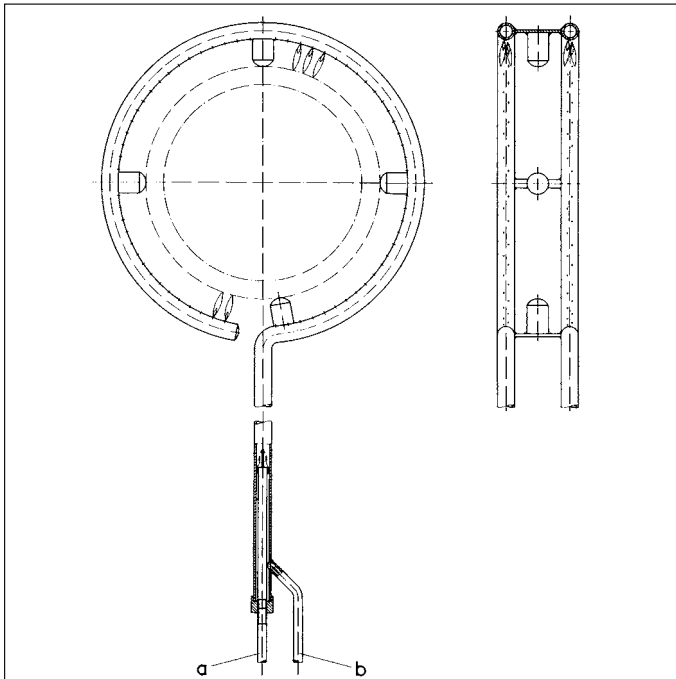

97: Ring burner for dismounting inner rings  
a = gas, b = air

# Dismounting

The surfaces of the hardened bearing rings are susceptible to overheating which reduces hardness and changes the dimensions. The burner should, therefore, always be held concentric to the bearing ring. The burner should be moved slowly and evenly across the bearing ring in the axial direction. This will avoid a tempering effect and additional stressing in the ring.

Sometimes heavy fretting corrosion or cold welding can make the regular removal of bearing rings impossible. In such cases which, of course, only apply to unserviceable rings, these are heated by a welding torch to 350°C and hosed with cold water. The heavy internal stresses thus produced in the ring will make it crack. Since the ring is likely to burst, the area of dismantling must be well screened or covered to avoid accidents.

Crack unserviceable rings for a removal

## Safety information

If - for example when a bearing is dismantled by means of a welding torch - a temperature of approx. 300°C and above is reached, fluorinated materials can release gases and vapours that are detrimental to human health. FAG uses fluorinated materials for seals made of fluoroelastomer (FKM, FPM, e. g. Viton®) or for fluorinated lubricating greases such as the rolling bearing grease Arcanol L79V. If high temperatures cannot be avoided, the safety data sheet valid for the fluorinated material in question has to be observed that can be obtained on request.

## 4.3 Hydraulic Method

With the hydraulic method, oil is injected between the mating surfaces. The oil film greatly reduces the friction between the mating parts which can then be conveniently displaced in relation to one another without the risk of damaging the mating surfaces (see chapter 3.3).

The hydraulic method is suitable for dismantling bearings with tapered and cylindrical bore. In both cases, oil grooves, ducts and threaded connections for the pump must be provided (Fig. 98). Larger adapter and withdrawal sleeves feature the corresponding grooves and holes (Figs. 101, 102).

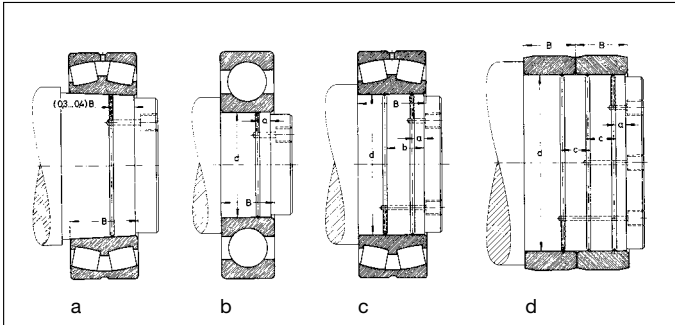

98: Position of oil grooves for dismounting by the hydraulic method.

- a: Tapered shaft seat;
- b: Cylindrical shaft seat, bearing width  $B \leq 80$  mm,  $a \approx \sqrt{d}$ ;
- c: Cylindrical shaft seat, bearing width  $B > 80$  mm,  $a \approx \sqrt{d}$ ;  
 $b \approx (0.5 \text{ to } 0.6) B$ ;
- d: Cylindrical shaft seat, two inner rings mounted side by side; bearing width  $B > 80$  mm;  
 $a \approx \sqrt{d}$ ,  $c \approx B - (1.5 \text{ to } 2) \sqrt{d}$

For dismounting tapered bore bearings directly seated on the shaft, injectors will do for pressure generation (Fig. 51). Cylindrical bore bearings and adapter and withdrawal sleeve mounted bearings require a pump (Fig. 52, chapter 3.3).

For dismounting, a thicker oil with a viscosity of about  $150 \text{ mm}^2/\text{s}$  (cSt) at  $20^\circ\text{C}$  (nominal viscosity  $46 \text{ mm}^2/\text{s}$  at  $40^\circ\text{C}$ ) can be used. If the contact surfaces are damaged, a high-viscosity oil of about  $1,150 \text{ mm}^2/\text{s}$  (cSt) at  $20^\circ\text{C}$  (nominal viscosity  $320 \text{ mm}^2/\text{s}$  at  $40^\circ\text{C}$ ) should be used. Fretting corrosion can be dissolved by anti-corrosive additives in the oil.

### 4.3.1 Dismounting of Tapered Bore Bearings

For hydraulic dismounting of bearings, mounted on a tapered journal, a withdrawal sleeve or an adapter sleeve, oil is pumped between the surfaces in contact. This releases the press fit instantly. The release being rather abrupt, a stop should be provided to control the movement. This may be a shaft or sleeve nut or any other convenient means (Figs. 99 to 102).

**Restrict axial movement!**



99: Dismounting a withdrawal sleeve mounted spherical roller bearing by the hydraulic method.

# Dismounting

## Dissolve fretting corrosion by the addition of rust solvents

The incidence of fretting corrosion may render dismounting more difficult. In this case, a rust-dissolving hydraulic oil should be used, especially for bearings of long service. For a seized withdrawal sleeve, the extra force required to set it moving can be applied through the withdrawal nut. If the withdrawal nut features thrust bolts (Fig. 103), a plate or washer should be inserted between the bolts and the bearing, to avoid damaging the lips of the bearing ring.

100: Bearing seated on shaft; the oil is pumped between the surfaces in contact; bearing disengages spontaneously. Stop to be left on shaft to restrict bearing movement.

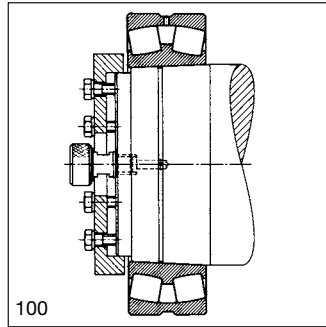

101: Bearing seated on withdrawal sleeve: Oil is pumped into withdrawal sleeve bore and O. D.; withdrawal sleeve disengages spontaneously. Nut to be left on shaft.

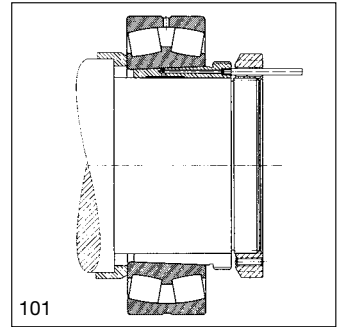

102 a-b: Adapter sleeve mounted bearing: Oil is pumped between adapter sleeve O. D. and bearing bore; Bearing disengages spontaneously. Stop to be left on sleeve.

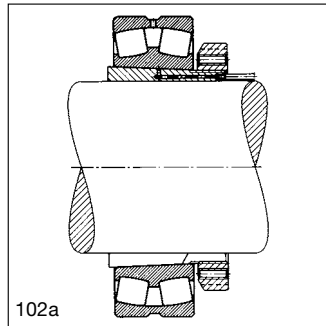

a: Oil connection in small end of sleeve

b: Oil connection in large end of sleeve

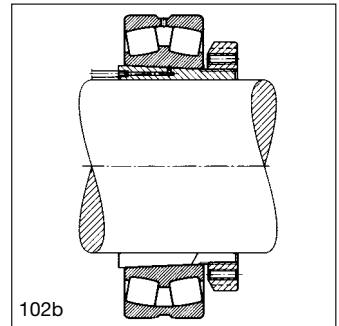

103: Dismounting in difficult cases: Oil containing rust solvents is pumped between the mating surfaces. Higher-viscosity oils should be used. Sleeve extraction is facilitated by applying nut provided with thrust bolts.

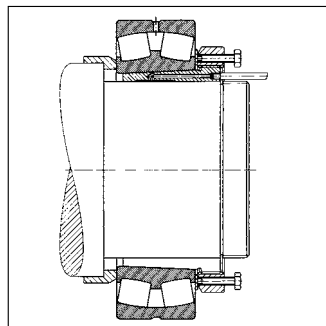

## 4.3.2 Dismounting of Cylindrical Bore Bearings

For cylindrical bore bearings, the use of the hydraulic technique is generally limited to dismounting.

The first step is to apply a bearing extractor to the bearing ring (Figs. 104 a-c). Then, hydraulic oil is pumped into the oil grooves.

When the bearing ring moves easily, it should be displaced far enough to expose the rear oil groove; the oil feed to this groove is stopped.

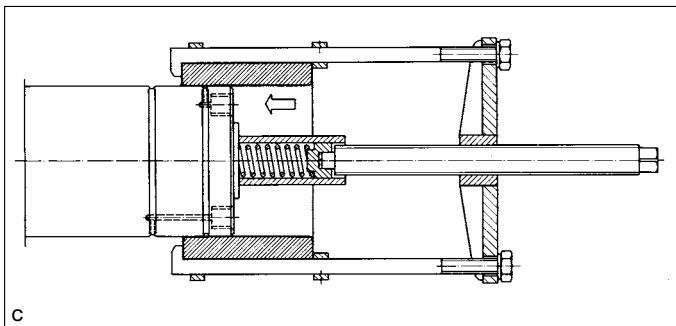
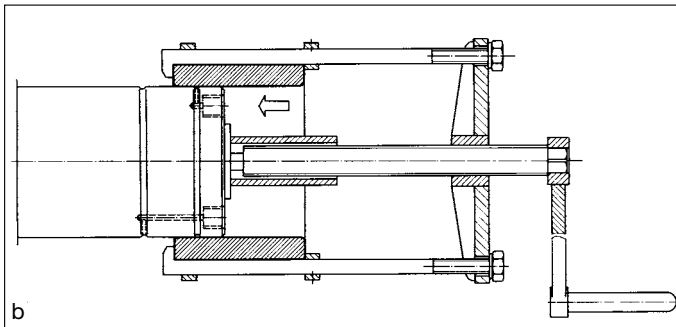
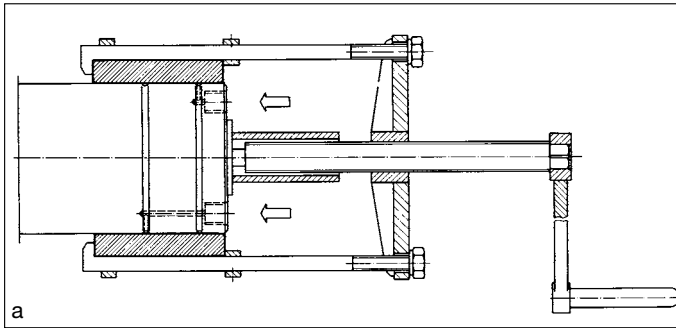

104: dismounting of a cylindrical bore inner ring with the hydraulic method

- a: Apply extractor to the inner ring and pump oil into the two oil grooves.
- b: Pull ring far enough to expose the rear oil groove and stop oil feed to this groove. The ring is given a further pull, until it covers the forward oil groove at either side by an identical length. The oil feed is stopped so that the ring will freeze.
- c: The extracting device is preloaded with a spring. Rebuilding the oil film enables the ring to slide off the shaft.

# Dismounting

Then the ring is given a further pull, until the ring covers the forward oil groove at either side by an identical length (Fig. 104 b).

The oil feed to the forward groove is stopped which means that the ring will freeze again. A spring is inserted into the guide sleeve of the extractor and preloaded (Fig. 104 c).

The travel stroke of the extractor spring should be a little greater than the length occupied by the ring on the shaft. Rebuilding the oil film by vigorous pumping enables the extractor to slide the ring off the shaft. It is recommended to catch the ring on its way off.

**Catch ring on its way off the shaft**

The spring preload should be approximately  $F = 20 \cdot d$  (F in N and d in mm). Whenever several rings are mounted on the shaft side by side, they are dismounted separately.

The displacement of the ring up to the point where the forward oil groove is still covered evenly, can generally be done by hand, since upon injection of the hydraulic oil, the rings are easily displaceable. The better the ring "floats" in the extraction phase, when the spring pressure pulls it from the shaft, the less the probability of its getting caught at the shaft end.

**Use oil injection ring for the removal of bearing from plain shafts**

In the absence of oil grooves and ducts in the shaft, the oil can be injected between the mating surfaces from the inner ring front face (Fig. 105). To this effect, a sealed oil injection ring is placed in front of the bearing feeding pressurized oil into the fitting joint. Mounting a sleeve to the shaft end allows oil to be pumped between the mating surfaces all the time the dismounting operation lasts. If the use of such a sleeve is not possible, a high-viscosity oil of 320 mm<sup>2</sup>/s (cSt) at 40°C must be used. An oil of this viscosity maintains an adequate oil film for approximately 5 minutes which is sufficient for bearing removal.

105: Special device for extracting a cylindrical bore spherical roller bearing from a shaft without oil grooves. The oil is fed into the fitting joint from the inner ring front face.

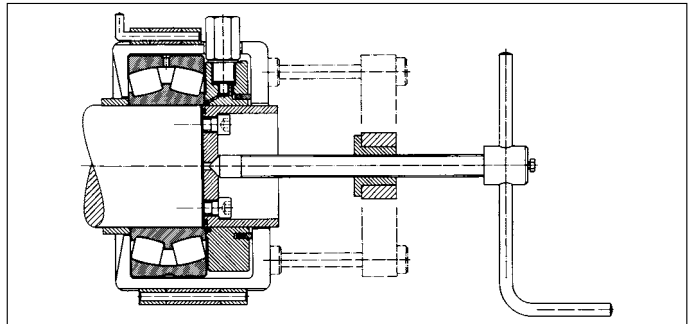

These special extracting devices are relatively complicated. They are, for example, used for applications where no oil grooves are provided in the shafts or axles for strength reasons, but which require frequent dismounting (e. g. for rail vehicles).

## 5. Lubrication

The primary purpose of the lubricant is to build a load-carrying film separating the bearing components in rolling and sliding contact in order to minimize friction and wear. The lubricant should also protect the bearing against corrosion. If required, it should also act as a sealant, and in case of circulating oil lubrication, as a coolant.

Due to deterioration and mechanical stressing, the lubricants become unuseable. Change of oil or grease or replenishment, i. e. bearing maintenance, has a favorable influence on the bearing service life. Under certain sealing and environmental conditions, appropriate lubricant selection allows for a lubrication for life. For detailed information see also FAG Publ. No. WL 81115 "Rolling Bearing Lubrication".

### 5.1 Greases

Only high-grade greases - generally on a metal soap basis - should be used. Rolling bearing greases for extreme temperatures contain different thickeners and a synthetic oil instead of the mineral oil.

**Only use time-tested greases**

Greases containing extreme pressure (EP) additives are used in high-load and low-speed applications. High-speed bearings and bearings which ask for low friction, are lubricated with greases containing a thin synthetic base oil.

The operating temperatures specified by the grease supplier should be kept in mind. Rolling bearing greases should be stable against deterioration and must not change their structure, even after long periods of operation.

**Consider grease application range**

# Lubrication

The table 7.23 on p. 113 lists the FAG rolling bearing greases Arcanol and their properties.

## 5.2 Oils

Only use time-tested oils

For rolling bearing lubrication, mineral oils are generally used. They should have the following properties:

Utmost cleanliness, stability against deterioration, good viscosity-temperature behaviour and good water repellency. In addition, the lubricating oil must ensure satisfactory protection of the bearing against corrosion. Very high and very low operating temperatures require the use of synthetic oils. Oils for highly loaded and low-speed bearings should contain EP-additives.

## 5.3 Selection of Lubricant

Greases are generally preferred to oils because they simplify maintenance and can be used as sealants. The asset of oil is that it readily feeds into all areas of contact and carries off heat. Its disadvantage is that it involves a more complex design of the bearing location and especially of the sealing system.

The following factors determine the selection of lubricant:

### Operating Temperature

Depending on the speed, the temperature of a bearing location is a function of bearing friction, lubricant friction, heat dissipation to the outside, and, as the case may be, heat supply from the outside.

Watch steady-state temperature

A bearing mounting is reliable, if the steady-state temperature settles at a level acceptable for the application. A continuous temperature increase, on the other hand, necessitates special measures (extra cooling, change-over to a different lubricant etc.). A short-term temperature rise occurs with grease relubrication.

The viscosity of lubricating oils decreases with increasing temperature and increases when the temperature drops. Preference should be given to oils the viscosity of which varies little with temperature (good V-T behaviour).

Watch viscosity at operating temperature

The higher the expected operating temperature, the higher should be the nominal viscosity of the oil. The nominal or mid-point viscosity is the viscosity for oils at 40°C. The oils are classified in viscosity grades (ISO VG) (DIN 51519).

The permissible temperature range of greases varies with the saponification bases. As a rule, the upper limits are:

Calcium soap base: + 50°C (120°F)

Sodium soap base: + 70°C (160°F) to 120°C (250°F)

Lithium soap base: + 110°C (230°F) to 130°C (265°F)

Diverse complex soap greases, gels, and greases containing entirely synthetic thickeners feature temperature limits beyond 130°C (265°F). Greases with thin synthetic base oils are especially applicable for low temperatures.

Exact values for the commercial greases are available from manufacturers' catalogues.

In selecting oils and greases, it should be borne in mind that a high temperature speeds up deterioration and decreases the lubricant service life.

Exact values of greases with different saponification bases are available from manufacturers' catalogues

## Loads and speed

Under the given operating conditions, the lubricant must form a load carrying lubricating film. With oil, the load carrying capacity of the film is primarily a function of viscosity. The lower the bearing speed, the higher the oil viscosity in operating condition. Information on viscosity  $v_1$  can be seen in the FAG catalogue WL 41520. Consideration must be given to the fact that bearing temperatures depend on load and speed. The operating temperature required for determination of the nominal viscosity must be estimated.

Increases in speed are associated with increasing lubricant friction and accordingly, increasing bearing temperature. The friction will be higher, the more viscous the lubricant is. On the other hand, higher temperatures lower viscosity which decreases the load carrying capacity of the lubricant film.

The permissible speeds for the various types and sizes of rolling bearings for grease and oil lubrication are listed in the FAG catalogues.

The use of solid lubricants as e. g. graphite and MoS<sub>2</sub> is limited to ultralow speeds and creeping motions only.

High-load applications call for oils containing EP additives. Greases for high-load applications are characterized by base oils of high viscosity and EP additives.

High-viscosity oils for low speeds

Observe relationship between speed, lubricant friction, temperature and viscosity

Permissible speeds for oil and grease lubrication see FAG Rolling Bearing Catalogues

Solid lubricants only for creeping speeds

# Lubrication

## Bearing Size

Small bearings are generally lubricated with a low-viscosity oil or with a very soft grease to minimize lubricant friction in the bearing. In large bearings, the lubricant friction plays a minor role, and the choice between oil or grease is, in this respect, of secondary importance.

## Moisture

Consider lubricant behaviour with moisture

The reaction of rolling bearing greases against moisture is different from one grease to the other. Only the water-repellent calcium base greases (Ca-greases) possess a safe sealing action against water. They are used, therefore, in labyrinths for operating temperatures not exceeding 50°C, acting as sealing agents.

The sodium base greases feature a higher limiting temperature than the calcium greases. They emulsify with water and are indicated for applications with a limited amount of moisture (e. g. condensation water). Since the sodium base greases are water-absorbing, there is the risk that so much water will be absorbed that they will wash out of the bearing.

Lithium base greases do not absorb as much water as sodium base greases. Because of their reasonable resistance to water and their wide temperature range they have become the greases of preference for rolling bearings.

Also with oils, their moisture and water resisting properties must be considered. Oils that separate water well should be preferred, because they allow the water to settle in the oil sump or reservoir when the machine is at rest.

The protection against corrosion is improved by anti-corrosive additives in the oils or greases.

## Contamination

Maintain cleanliness of lubricant reservoir, lubricators and grease nipples.

Relubrication involves the risk of bearing contamination. High standards of cleanliness should, therefore, be maintained for the lubricant reservoir and the lubricators and also when handling the lubricant. Grease nipples should be cleaned before relubrication.

## Mixing of Lubricants

Never mix different lubricants

Lubricants of different saponification bases should not be mixed to avoid impairment of temperature stability and lubricating properties. The same applies to oils.

## Lubricant Quantity

With grease lubrication, the bearing cavities should be packed to capacity. Only partly fill (20 to 35% of free space) extremely fast running bearings. The amount of grease to be filled into both lateral housing cavities depends on  $n \cdot d_m$ .

( $n$  = maximum operating speed

$$d_m = \frac{D+d}{2} \text{ mean bearing diameter)}$$

Speed index	Amount of grease filled in the housing space
$n \cdot d_m < 50000 \text{ min}^{-1} \cdot \text{mm}$	full
$n \cdot d_m = 50000 \text{ up to } 500000 \text{ min}^{-1} \cdot \text{mm}$	60%

Overgreasing at medium and higher speeds causes churning resulting in an undesirable temperature rise which may harm both bearing and lubricant.

Rolling bearings with seals or shields are packed with grease to approx. 35% only during manufacture.

With oil lubrication, too much oil in the housing has similarly detrimental effects: the churning action overheats the oil and exposes it to air oxygen, causing oxidation and foaming.

With sump lubrication, the oil level in the housing should be no higher than the centre point of the lowest ball or roller when the bearing is at rest.

# 6. Rolling Bearing Damage

## 6. Rolling Bearing Damage

The life of a rolling bearing depends on the total number of stress cycles and the loads incurred by rolling elements and raceways.

The standardized calculation method for dynamically stressed bearings is based on material fatigue (pitting) causing the damage.

Normal fatigue manifests itself by flaking or spalling of the rolling surfaces (Fig. 106). An increasing local stress may result in fracture of the ring (Fig. 107).

If the bearing fails earlier than predicted by the life calculation, it should be checked for overloading. With this failure cause excluded, faulty mounting or poor maintenance or wear might be the cause for the damage. The following pages describe some of the more common forms of bearing damage and their causes.

106: Flaked inner ring of a deep groove ball bearing



107: Fracture of the inner ring of a deep groove ball bearing as final stage of fatigue

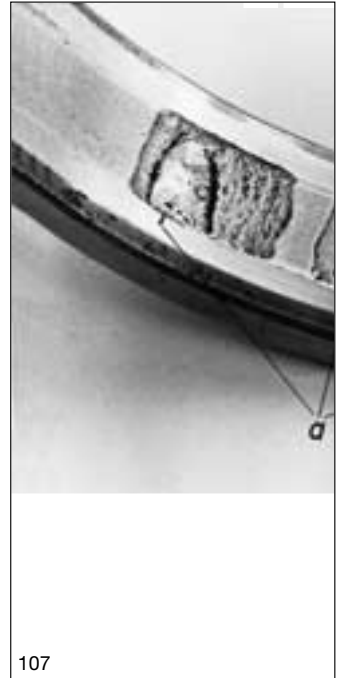

## 6.1 Why Does a Bearing Fail?

### 6.1.1 Faulty Mounting

Local damage to the raceways, such as nicks, score marks or indentations suggest faulty mounting. This type of damage occurs, if, for instance, the inner ring of a cylindrical roller bearing is inserted out-of-square into the outer ring, or if the mounting force is applied through the rolling elements (Figs. 108 to 111).

Surface damage is also caused, when foreign particles enter the bearing and are cycled (see chapter 6.1.2).

The damage can be recognized for instance by a louder running noise; in the long run, it may lead to premature fatigue of the functional surfaces.

The typical sign for surface damage are the raised edges of the indentations.



108: Ball indentations in the raceway of a deep groove ball bearing resulting from faulty mounting

# Rolling Bearing Damage

109: Scored raceway of a cylindrical roller bearing inner ring



110: Premature fatigue of a cylindrical roller bearing outer ring caused by score marks visible at "a"

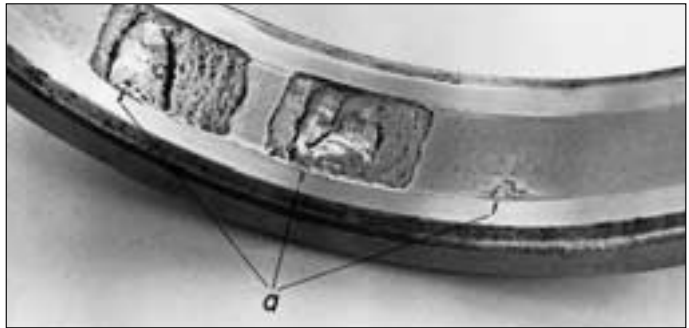

111: Fractured lip of a barrel roller bearing inner ring driven up its seat by hammer blows



The location of the load zone in a bearing ring results from the direction of the externally applied loads and from the conditions of rotation. The load zone can soon be recognized by slight frosting on the raceways indicating whether the bearing was loaded as specified.

# Rolling Bearing Damage



112: Running tracks caused by off-square mounting of a stationary deep groove ball bearing inner ring

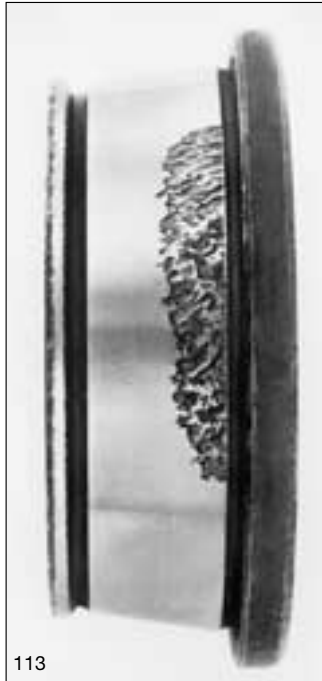

113: One-sided flaking caused by off-square mounting of a stationary tapered roller bearing cone

Unusual running tracks suggest detrimental preloading which may be caused by too tight fits, excessive axial adjustment, form inaccuracies of shaft or housing, misalignment or by a tight fit of the floating bearing (Figs. 112 and 113).

## 6.1.2 Contamination

Foreign particle indentations in the functional surfaces may lead to premature fatigue (see chapter 6.1.1). Foreign particles with abrasive effect, however, accelerate bearing failure due to wear. The surfaces are roughened and look dull. Progressive wear causes excessive clearance.

Possible causes:

- Contaminated parts
- Moulding sand in housings
- Inadequate seals
- Contaminated lubricants
- Metallic abrasion from gears brought into the bearing by the lubricant.

# Rolling Bearing Damage

## 6.1.3 Corrosion

Corrosion in rolling bearings may occur in various forms and have different causes. The damage shows in an uneven and loud running noise. The rust abraded by the rolling elements causes wear.

Figures 114 and 115 show corrosion damage due to moisture or other corrosive media.

Possible causes:

Inadequate sealing against moisture,  
acid fumes,  
lubricants containing acids,  
condensation,  
unsuitable storage of the rolling bearings in the warehouse.

False brinelling is identified by marks in the raceways at rolling element spacing. In contrast to the rolling element indentations caused by incorrect mounting, they have no raised edges (Fig. 116). The increased number of indentations shown in Fig. 117 is a result of occasional turning of the bearing.

False brinelling is caused by vibrations in the contact areas of parts while these are stationary, resulting in wear. Susceptible to such damage are machines which are subjected to vibrations while stationary or during transportation. Possible remedy: Securing by wedges

114: Corrosion of tapered roller bearing cone



115: Corrosion marks in the raceway of a self-aligning ball bearing outer ring



# Rolling Bearing Damage

or similar means for transportation or keeping the bearing in rotation (e. g. on ships).

Fretting corrosion, however, occurs at the fitting surfaces, i. e. in the bearing bore or at the bearing outside diameter. It is caused by relatively loose fits or too soft mating components. Minute motions (micro-slipping) in the fitting joint may cause heavy wear resulting in an impeded floating bearing function or fracture of the shaft due to notch stresses. Possible remedy: Tight bearing fits or reinforcement of mating structure.

## 6.1.4 Passage of Electric Current

Continuous passage of electric current causes brownish flutes parallel to the axis over the entire circumference of one or both raceways as well as on the rolling elements (Fig. 118 and 119).

## 6.1.5 Imperfect Lubrication

Starved lubrication is caused by an insufficient lubricant supply or by use of an improper lubricant. If the lubricating film does not sufficiently separate the parts in rolling contact, sliding motion and wear result. Since maximum material stressing occurs at the raceway surfaces, micro pits and consequently large-area superficial flaking is produced (Fig. 120).



116: Indents caused by false brinelling of the raceway of a self-aligning ball bearing outer ring

117: False brinelling in the raceway of a cylindrical roller bearing inner ring - due to vibrations

# Rolling Bearing Damage

118: Fluted rollers of a spherical roller bearing due to the passage of electric current



119: Fluted raceway of a spherical roller bearing outer ring due to the passage of electric current

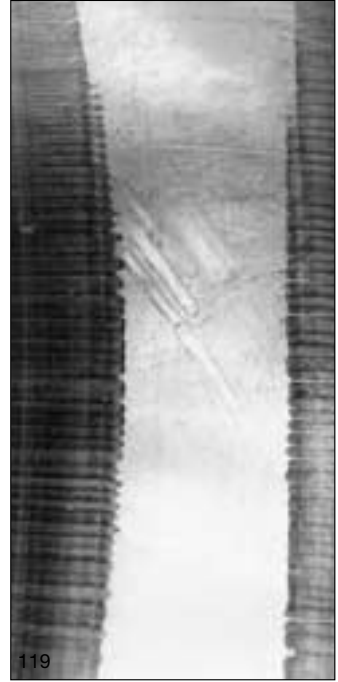

In the case of overlubrication, the lubricant heats up due to the churning action and loses its lubricity. Overheating, i. a. catastrophic failure of the bearing, may be the result. Prevent lubricant retention within the bearing, especially for high-speed bearings.

The possible consequences of contaminated lubricants are described in chapter 6.1.2.

120: A non load-carrying lubricating film causes large-area superficial flaking on cylindrical rollers.

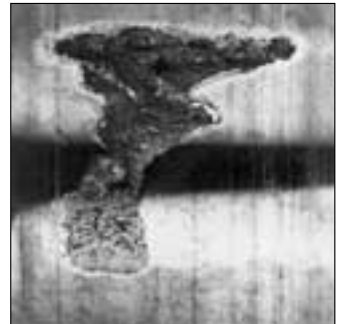
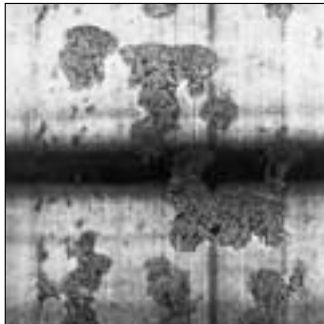

# Rolling Bearing Damage

## 6.2 How to Recognize Bearing Damage in Operation?

Symtoms	Source of Trouble	Examples
Uneven running	<p>Damaged rings or rolling elements</p> <p>Contamination</p> <p>Excessive clearance</p>	<p>Motor vehicles: Increased wheel wobble and vibration of steering system</p> <p>Fans: Increasing vibration</p> <p>Sawmills: Increasing knocking in connection rods</p> <p>Combustion engines: Increased vibration in crankshaft</p>
Reduced working accuracy	<p>Wear due to contaminants or insufficient lubrication</p> <p>Damaged rings or rolling elements</p>	<p>Lathe: Gradual development of chatter marks on workpiece</p> <p>Grinders: Waviness of ground surface</p> <p>Cold Rolling Mill: Period surface defects on rolled material such as stretcher strains, ghost lines etc.</p>
Unusual running noise: Whining or high pitched noise	Insufficient operating clearance	Electric motors, gears; with gearboxes, the bearing noise is hard to identify, since it is generally drowned in the running noise of the gears
Low pitched rumbling or irregular noise	<p>Excessive operating clearance</p> <p>Damaged running surfaces</p> <p>Contamination</p> <p>Inadequate lubricant</p>	
Gradual change in running noise	<p>Changes in operating clearance caused by temperature.</p> <p>Damaged raceway (from contamination or fatigue)</p>	

# Rolling Bearing Damage

## 6.3 How to Pinpoint Bearing Damage?

The examples shown in Figs. 106 to 120 are striking damage cases. They can be clearly defined and diagnosed. A detailed discussion of all imaginable combinations of bearing damage would certainly go beyond the scope of this manual.

In the field, the diagnosis of the primary cause of failure is not always easy. In many cases an examination of, for instance, the running tracks, allows certain conclusions to be drawn. Advice for the avoidance of future trouble can, however, hardly be given without knowing operating conditions, lubrication and overall design of the machine. Information should, moreover, be available on the damage symptoms in evidence and on relevant secondary phenomena.

### 6.3.1 Observations prior to Dismounting

Prior to dismounting, the following four conditions should be surveyed and the survey result be made a matter of record. The importance of this procedure cannot be overemphasized, since, after bearing dismounting and cleaning of bearing and housing, this evidence is irretrievably lost.

#### Contamination

What are the overall conditions of the machine, particularly near the bearing location? Are there deposits of dirt or residues of the machined or processed material? Could water, caustics, cutting fluids, vapours and fumes have entered the bearing housing?

#### Loss of Lubricant

Was there any chance of lubricant escape? To find out, check the oil gauge level and the sealing gaps at the shaft outlet, all joints between housing and cover, and the seals of the oil pipes, drain plug and oil gauge.

#### Running Noise

Bearing damage can frequently be recognized by changes in the running noise. The nature of the noise should be specified as exactly as possible by indicating whether it is even or pulsating, recurrent or nonrecurrent, rumbling, whining, singing, or knocking. If the noise is recurrent, its frequency should be recorded. For higher speeds, this may require complicated recording equipment; for low speeds,

Keep track of operating behaviour and record observations

# Rolling Bearing Damage

however, it has been found practical to tap with a pencil on a piece of paper at the rate of noise recurrency, and to count the dots after a given number of seconds. The result should give a clue as to whether the trouble occurs, for instance, at inner ring or cage frequency. An attempt should also be made to assess the noise level.

**Keep track of behaviour and record observations**

Before disassembly, the bearing should once more be turned by hand. Often this allows easy identification and accurate characterization of running irregularities.

## Case History and Secondary Evidence

The damage should be recorded, while still fresh in mind. It is important that all details be listed, i. e. the time the malfunction was first noticed, the initial symptoms and the alterations in noise or temperature occurring with time. If the trouble starts suddenly, the position of the control handles and the operating position of the machine should be noted. Any former modifications made on the machine, for instance clearance adjustment, installation of new shafts, sleeves, or spacers, increases in capacity and speed should be included in the analysis. When these modifications and the onset of the bearing trouble coincide, the expert will certainly be able to draw significant conclusions.

### 6.3.2 Observations during Dismounting

The following four conditions should be watched:

#### Lubrication

In order to examine the cause of failure of the dismounted bearing, the lubricant must not be removed. Even an expert cannot define the cause of failure of a damaged, but cleaned bearing. Avoid additional contamination of the damaged bearing.

**Do not wash out lubricant, but take samples**

#### Oil Lubrication

With oil-lubricated bearings, the oil and, as the case may be, the coolant, are drained. The oil should be collected in a clean container, especially, if there is suspicion of dirt, metal chips or an unusual amount of grit from nearby gears. If the suspicion proves true, enough oil will thus be available for a thorough investigation.

# Rolling Bearing Damage

## Grease Lubrication

Dismounting of grease-lubricated bearings starts with the removal of covers, caps or shields. These parts should not be immediately washed out, but stored in a clean place, until the nature of bearing failure is clarified. The same applies to felt and rubber seals and to any other seals and shields. Even if maintenance instructions call for the installation of new seals at each overhaul, the old ones should be kept for some time, as their condition may be indicative of the efficiency of the sealing system.

Two grease samples should be taken, one from the bearing interior and another from the housing. Dirty grease nipples may contaminate grease used for relubrication; in this case a sample should be taken from the grease duct.

A generous quantity should always be sampled. The sampled grease should be kept in clean containers or spread on clean oil-paper and identified such that its origin can be traced back any time.

## Looseness of Locating Devices

Check tightness of locating nuts

As dismounting progresses, check tightness of the nuts which provide for axial location of the bearing inner ring. This is of particular importance with double row angular contact ball bearings with split inner ring, and with four-point bearings. Any loosening of axial location entails a change in bearing kinematics and clearance. This also applies to tapered roller bearings and angular contact ball bearings mounted in opposition. In the case of adapter and withdrawal sleeves and tapered seats, the tightness of the clamping or locknuts should be checked.

## Position of Bearing Rings

Upon removal of the nuts, the ring faces should be cleaned to check the position of the rings relative to the housing and the shaft.

Prepare sketch of bearing arrangement

Generally, the running tracks on the raceways give sufficient evidence of the direction of load; this evidence is, however, of little value, if the running tracks are unusual and nothing is known on how the outer ring was mounted in the housing and the inner ring on the shaft. For this purpose, a sketch should be made showing the position of the bearing number stamping relative to a reference point in the housing or on the shaft. The sketch should also show the direction into which the stamped face of the bearing ring points, i. e. towards the shaft center or the shaft end. For separable bearings, such as cylindrical roller bearings, magneto bearings and four-point bearings, this applies to both rings. If, upon disassembly, the running tracks are found to be unusual, conclusions can be drawn as to the type and direction of load, perhaps also on detrimental preload, furnishing a clue to the cause of damage.

# Rolling Bearing Damage

## Examination of Bearing Seats

When extracting the bearing, a note should be made of any unusually easy or difficult removal of the rings from their seats. The bearing components of separable bearings must be kept together and not be mixed up with parts of other bearings.

An inspection of the adjacent machine parts should be made at the same time, especially when the machine has to be quickly reassembled with the new bearings to avoid a prolonged close-down. The shaft and housing seat diameters should always be measured. Special care should be given to the roundness of the seats. The condition of the driving and the driven machine elements, especially of gears and other moving parts, should also be inspected. Sliding marks and the contact pattern will frequently furnish evidence on the shaft misalignment.

Measure shaft and housing diameter, check roundness of seat

### 6.3.3 Bearing Inspection

Upon completion of dismantling, the damaged bearing itself should be examined. Check cleanliness, condition of the mating surfaces (dimensional stability) and function (bearing clearance, smooth running) of the complete bearing. The damage in evidence on the bearing and the recorded secondary phenomena are, in most cases, sufficient to obtain a clear picture of the damage history. Doubtful cases should be reported to the nearest FAG Engineering Office.

In case of doubt, contact the nearest FAG Engineering Office

There are, of course, many applications where no necessity exists for going into such detail. This is the case with machines built in large numbers, where the "weak points" are known. Neither will one go to great lengths with low-cost bearings. However, in customer built or special purpose machines where a seemingly unexplainable bearing damage occurs, the described secondary evidence should, in any case, be a valuable diagnostic aid.



## 7.1 Bearing Designation

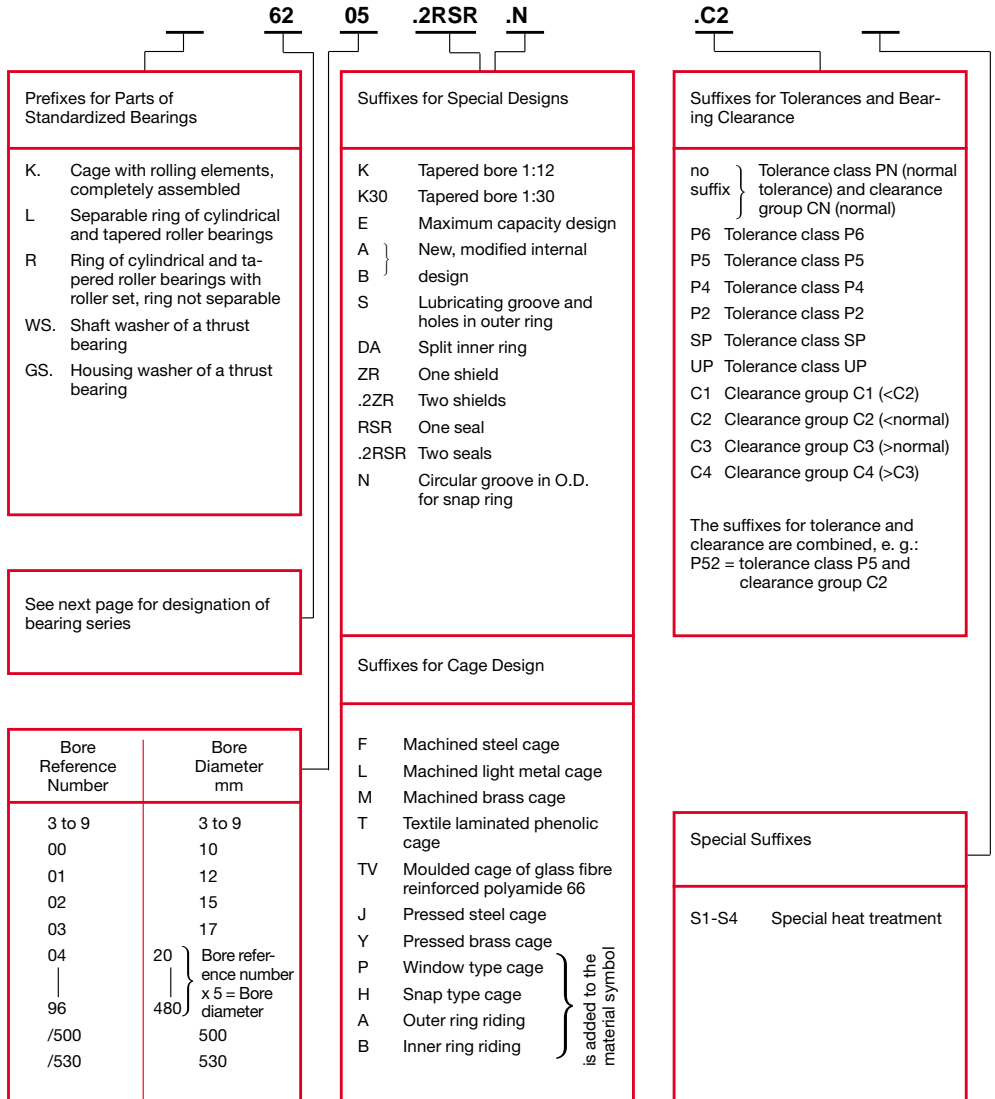

# Tables

## 7.2 Designation of Bearing Series: Ball Bearings

Bearing Series	Ball Bearings									Width or Height Series	Diameter Series
	Deep Groove Ball Bearings	Angular Contact Ball Bearings	Self-Aligning Ball Bearings	Thrust Ball Bearings	Angular Contact Thrust Ball Bearings	Single Row or Single Direction	Double Row or Double Direction	With Flat Housing Washer	With Spherical Housing Washer		
618	x					x				1	8
160	x					x				0	0
60	x					x				1	0
62	x					x				0	2
63	x					x				0	3
64	x					x				0	4
42	x						x			2	2
43	x						x			2	3
12			x				x			0	2
112			x				x			0	2
13			x				x			0	3
113			x				x			0	3
22			x				x			2	2
23			x				x			2	3
B 719		x				x				1	9
B 70		x				x				1	0
B 72		x				x				0	2
72		x				x				0	2
73		x				x				0	3
QJ 2		x				x				0	2
QJ 3		x				x				0	3
32		x					x			3	2
33		x					x			3	3
511				x		x		x		1	1
512				x		x		x		1	2
513				x		x		x		1	3
514				x		x		x		1	4
532				x		x			x		2
533				x		x			x		3
534				x		x			x		4
522				x			x	x		2	2
523				x			x	x		2	3
524				x			x	x		2	4
542				x			x		x		2
543				x			x		x		3
544				x			x		x		4
2344					x		x				
2347					x		x				
7602					x	x					
7603					x	x					

## 7.2 Designation of Bearing Series: Roller Bearings

Bearing Series	Roller Bearings						Single Row	Double Row	Width or Height Series	Diameter Series
	Cylindrical Roller Bearings	Tapered Roller Bearings	Barrel Roller Bearings	Type	Spherical Roller Bearings	Cylindrical Roller Thrust Bearings				
<b>N 2; NU 2; NJ 2; NUP 2</b>	x						x		0	2
<b>N 3; NU 3; NJ 3; NUP 3</b>	x						x		0	3
<b>N 4; NU 4; NJ 4; NUP 4</b>	x						x		0	4
<b>NU 10</b>	x						x		1	0
<b>NU 22; NJ 22; NUP 22</b>	x						x		2	2
<b>NU 23; NJ 23; NUP 23</b>	x						x		2	3
<b>NN 30</b>	x							x	3	0
<b>NNU 49</b>	x							x	4	9
<b>302</b>		x					x		0	2
<b>303</b>		x					x		0	3
<b>313</b>		x					x		1	3
<b>320</b>		x					x		2	0
<b>322</b>		x					x		2	2
<b>323</b>		x					x		2	3
<b>329</b>		x					x		2	9
<b>330</b>		x					x		3	0
<b>331</b>		x					x		3	1
<b>332</b>		x					x		3	2
<b>202</b>			x				x		0	2
<b>203</b>			x				x		0	3
<b>204</b>			x				x		0	4
<b>213</b>				x				x	0	3
<b>222</b>				x				x	2	2
<b>223</b>				x				x	2	3
<b>230</b>				x				x	3	0
<b>231</b>				x				x	3	1
<b>232</b>				x				x	3	2
<b>233</b>				x				x	3	3
<b>239</b>				x				x	3	9
<b>240</b>				x				x	4	0
<b>241</b>				x				x	4	1
<b>292</b>						x	x		9	2
<b>293</b>						x	x		9	3
<b>294</b>						x	x		9	4
<b>811</b>					x		x		1	1
<b>812</b>					x		x		1	2

# Tables

## 7.3 Shaft Tolerances

Dimensions in mm

Nominal shaft diameter	over to	<b>3</b> <b>6</b>	<b>6</b> <b>10</b>	<b>10</b> <b>18</b>	<b>18</b> <b>30</b>	<b>30</b> <b>50</b>	<b>50</b> <b>65</b>	<b>65</b> <b>80</b>	<b>80</b> <b>100</b>	<b>100</b> <b>120</b>	<b>120</b> <b>140</b>	<b>140</b> <b>160</b>	<b>160</b> <b>180</b>	<b>180</b> <b>200</b>
------------------------	---------	----------------------	-----------------------	------------------------	------------------------	------------------------	------------------------	------------------------	-------------------------	--------------------------	--------------------------	--------------------------	--------------------------	--------------------------

Tolerance in microns (normal tolerance)

Bearing bore diameter	Deviation $\Delta_{\text{dmp}}$	0 -8	0 -8	0 -8	0 -10	0 -12	0 -15	0 -15	0 -20	0 -20	0 -25	0 -25	0 -25	0 -30
-----------------------	---------------------------------	---------	---------	---------	----------	----------	----------	----------	----------	----------	----------	----------	----------	----------

Diagram of fit  
Shaft

Bearing

Shaft tolerance in microns

<b>e 7</b>		-20 -32	-25 -40	-32 -50	-40 -61	-50 -75	-60 -90	-60 -90	-72 -107	-72 -107	-85 -125	-83 -125	-85 -125	-100 -146
<b>e 8</b>		-20 -38	-25 -47	-32 -59	-40 -73	-50 -89	-60 -106	-60 -106	-72 -126	-72 -126	-85 -148	-85 -148	-85 -148	-100 -172
<b>f 6</b>		-10 -18	-13 -22	-16 -27	-20 -33	-25 -41	-30 -49	-30 -49	-36 -58	-36 -58	-43 -68	-43 -68	-43 -68	-50 -79
<b>f 7</b>		-10 -22	-13 -28	-16 -34	-20 -41	-25 -50	-30 -60	-30 -60	-36 -71	-36 -71	-43 -83	-43 -83	-43 -83	-50 -96
<b>g 5</b>		-4 -9	-5 -11	-6 -14	-7 -16	-9 -20	-10 -23	-10 -23	-12 -27	-12 -27	-14 -32	-14 -32	-14 -32	-15 -35
<b>g 6</b>		-4 -12	-5 -14	-6 -17	-7 -20	-9 -25	-10 -29	-10 -29	-12 -34	-12 -34	-14 -39	-14 -39	-14 -39	-15 -44
<b>h 5</b>		0 -5	0 -6	0 -8	0 -9	0 -11	0 -13	0 -13	0 -15	0 -15	0 -18	0 -18	0 -18	0 -20
<b>h 6</b>		0 -8	0 -9	0 -11	0 -13	0 -16	0 -19	0 -19	0 -22	0 -22	0 -25	0 -25	0 -25	0 -29
<b>j 5</b>		+3 -2	+4 -2	+5 -3	+5 -4	+6 -5	+6 -7	+6 -7	+6 -9	+6 -9	+7 -11	+7 -11	+7 -11	+7 -13
<b>j 6</b>		+6 -2	+7 -2	+8 -3	+9 -4	+11 -5	+12 -7	+12 -7	+13 -9	+13 -9	+14 -11	+14 -11	+14 -11	+16 -13
<b>js 3</b>		+1,25 -1,25	+1,25 -1,25	+1,5 -1,5	+2 -2	+2 -2	+2,5 -2,5	+2,5 -2,5	+3 -3	+3 -3	+4 -4	+4 -4	+4 -4	+5 -5
<b>js 4</b>		+2 -2	+2 -2	+2,5 -2,5	+3 -3	+3,5 -3,5	+4 -4	+4 -4	+5 -5	+5 -5	+6 -6	+6 -6	+6 -6	+7 -7
<b>js 5</b>		+2,5 -2,5	+3 -3	+4 -4	+4,5 -4,5	+5,5 -5,5	+6,5 -6,5	+6,5 -6,5	+7,5 -7,5	+7,5 -7,5	+9 -9	+9 -9	+9 -9	+10 -10
<b>js 6</b>		+4 -4	+4,5 -4,5	+5,5 -5,5	+6,5 -6,5	+8 -8	+9,5 -9,5	+9,5 -9,5	+11 -11	+11 -11	+12,5 -12,5	+12,5 -12,5	+12,5 -12,5	+14,5 -14,5
<b>k 3</b>		+2,5 0	+2,5 0	+3 0	+4 0	+4 0	+5 0	+5 0	+6 0	+6 0	+8 0	+8 0	+8 0	+10 0
<b>k 4</b>		+5 +1	+5 +1	+6 +1	+8 +2	+9 +2	+10 +2	+10 +2	+13 +3	+13 +3	+15 +3	+15 +3	+15 +3	+18 +4
<b>k 5</b>		+6 +1	+7 +1	+9 +1	+11 +2	+13 +2	+15 +2	+15 +2	+18 +3	+18 +3	+21 +3	+21 +3	+21 +3	+24 +4
<b>k 6</b>		+9 +1	+10 +1	+12 +1	+15 +2	+18 +2	+21 +2	+21 +2	+25 +3	+25 +3	+28 +3	+28 +3	+28 +3	+33 +4

200	225	250	280	315	355	400	450	500	560	630	710	800	900	1000	1120	1250
225	250	280	315	355	400	450	500	560	630	710	800	900	1000	1120	1250	

0	0	0	0	0	0	0	0	0	0	0	0	0	0	0	0	0
-30	-30	-35	-35	-40	-40	-45	-45	-50	-50	-75	-75	-100	-100	-125	-125	

-100	-100	-110	-110	-125	-125	-135	-135	-145	-145	-160	-160	-170	-170	-195	-195	
-146	-146	-162	-162	-182	-182	-198	-198	-215	-215	-240	-240	-260	-260	-300	-300	

-100	-100	-110	-110	-125	-125	-135	-135	-145	-145	-160	-160	-170	-170	-195	-195	
-172	-172	-191	-191	-214	-214	-232	-232	-255	-255	-285	-285	-310	-310	-360	-360	

-50	-50	-56	-56	-62	-62	-68	-68	-76	-76	-80	-80	-86	-86	-98	-98	
-79	-79	-88	-88	-98	-98	-108	-108	-120	-120	-130	-130	-142	-142	-164	-164	

-50	-50	-56	-56	-62	-62	-68	-68	-76	-76	-80	-80	-86	-86	-98	-98	
-96	-96	-108	-108	-119	-119	-131	-131	-146	-146	-160	-160	-176	-176	-203	-203	

-15	-15	-17	-17	-18	-18	-20	-20	-22	-22	-24	-24	-26	-26	-28	-28	
-35	-35	-40	-40	-43	-43	-47	-47	-51	-51	-56	-56	-62	-62	-70	-70	

-15	-15	-17	-17	-18	-18	-20	-20	-22	-22	-24	-24	-26	-26	-28	-28	
-44	-44	-49	-49	-54	-54	-60	-60	-66	-66	-74	-74	-82	-82	-94	-94	

0	0	0	0	0	0	0	0	0	0	0	0	0	0	0	0	
-20	-20	-23	-23	-25	-25	-27	-27	-29	-29	-32	-32	-36	-36	-42	-42	

0	0	0	0	0	0	0	0	0	0	0	0	0	0	0	0	
-29	-29	-32	-32	-36	-36	-40	-40	-44	-44	-50	-50	-56	-56	-66	-66	

+7	+7	+7	+7	+7	+7	+7	+7									
-13	-13	-16	-16	-18	-18	-20	-20									

+16	+16	+16	+16	+18	+18	+20	+20	+22	+22	+25	+25	+28	+28	+33	+33	
-13	-13	-16	-16	-18	-18	-20	-20	-22	-22	-25	-25	-28	-28	-33	-33	

+5	+5	+6	+6	+6,5	+6,5	+7,5	+7,5									
-5	-5	-6	-6	-6,5	-6,5	-7,5	-7,5									

+7	+7	+8	+8	+9	+9	+10	+10									
-7	-7	-8	-8	-9	-9	-10	-10									

+10	+10	+11,5	+11,5	+12,5	+12,5	+13,5	+13,5	+14,5	+14,5	+16	+16	+18	+18	+21	+21	
-10	-10	-11,5	-11,5	-12,5	-12,5	-13,5	-13,5	-14,5	-14,5	-16	-16	-18	-18	-21	-21	

+14,5	+14,5	+16	+16	+18	+18	+20	+20	+22	+22	+25	+25	+28	+28	+33	+33	
-14,5	-14,5	-16	-16	-18	-18	-20	-20	-22	-22	-25	-25	-28	-28	-33	-33	

+10	+10	+12	+12	+13	+13	+15	+15									
0	0	0	0	0	0	0	0									

+18	+18	+20	+20	+22	+22	+25	+25									
+4	+4	+4	+4	+4	+4	+5	+5									

+24	+24	+27	+27	+29	+29	+32	+32	+29	+29	+32	+32	+36	+36	+42	+42	
+4	+4	+4	+4	+4	+4	+5	+5	0	0	0	0	0	0	0	0	

+33	+33	+36	+36	+40	+40	+45	+45	+44	+44	+50	+50	+56	+56	+66	+66	
+4	+4	+4	+4	+4	+4	+5	+5	+0	+0	+0	+0	+0	+0	+0	+0	

# Tables

## 7.3 Shaft Tolerances (continuation)

Dimensions in mm

Nominal shaft diameter	over to	3 6	6 10	10 18	18 30	30 50	50 65	65 80	80 100	100 120	120 140	140 160	160 180	180 200
------------------------	---------	--------	---------	----------	----------	----------	----------	----------	-----------	------------	------------	------------	------------	------------

Tolerance in microns (normal tolerance)

Bearing bore diameter	0	0	0	0	0	0	0	0	0	0	0	0	0	0
Deviation $\Delta_{\text{dmp}}$	-8	-8	-8	-10	-12	-15	-15	-20	-20	-25	-25	-25	-25	-30

Diagram of fit  
Shaft Bearing

Shaft tolerance in microns

<b>m 5</b>		+9 +4	+12 +6	+15 +7	+17 +8	+20 +9	+24 +11	+24 +11	+28 +13	+28 +13	+33 +15	+33 +15	+33 +15	+37 +17
<b>m 6</b>		+12 +4	+15 +6	+18 +7	+21 +8	+25 +9	+30 +11	+30 +11	+35 +13	+35 +13	+40 +15	+40 +15	+40 +15	+46 +17
<b>n 5</b>		+13 +8	+16 +10	+20 +12	+24 +15	+28 +17	+33 +20	+33 +20	+38 +23	+38 +23	+45 +27	+45 +27	+45 +27	+51 +31
<b>n 6</b>		+16 +8	+19 +10	+23 +12	+28 +15	+33 +17	+39 +20	+39 +20	+45 +23	+45 +23	+52 +27	+52 +27	+52 +27	+60 +31
<b>p 6</b>		+20 +12	+24 +15	+29 +18	+35 +22	+42 +26	+51 +32	+51 +32	+59 +37	+59 +37	+68 +43	+68 +43	+68 +43	+79 +50
<b>p 7</b>		+24 +12	+30 +15	+36 +18	+43 +22	+51 +26	+62 +32	+62 +32	+72 +37	+72 +37	+83 +43	+83 +43	+83 +43	+96 +50
<b>r 6</b>		+23 +15	+28 +19	+34 +23	+41 +28	+50 +34	+60 +41	+62 +43	+73 +51	+76 +54	+88 +63	+90 +65	+93 +68	+106 +77
<b>r 7</b>		+27 +15	+34 +19	+41 +23	+49 +28	+59 +34	+71 +41	+73 +43	+86 +51	+89 +54	+103 +63	+105 +65	+108 +68	+123 +77
<b>s 6</b>		+27 +19	+32 +23	+39 +28	+48 +35	+59 +43	+72 +53	+78 +59	+93 +71	+101 +79	+117 +92	+125 +100	+133 +108	+151 +122
<b>s 7</b>		+31 +19	+38 +23	+46 +28	+56 +35	+68 +43	+83 +53	+89 +59	+106 +71	+114 +79	+132 +92	+140 +100	+148 +108	+168 +122

Shaft tolerance for withdrawal sleeves and adapter sleeves (microns)

<b>h7/IT5</b>		0 -12 2,5	0 -15 3	0 -18 4	0 -21 4,5	0 -25 5,5	0 -30 6,5	0 -30 6,5	0 -35 7,5	0 -35 7,5	0 -40 9	0 -40 9	0 -40 9	0 -46 10
<b>h8/IT5</b>		0 -18 2,5	0 -22 3	0 -27 4	0 -33 4,5	0 -39 5,5	0 -46 6,5	0 -46 6,5	0 -54 7,5	0 -54 7,5	0 -63 9	0 -63 9	0 -63 9	0 -72 10
<b>h9/IT6</b>		0 -30 4	0 -36 4,5	0 -43 5,5	0 -52 6,5	0 -62 8	0 -74 9,5	0 -74 9,5	0 -87 11	0 -87 11	0 -100 12,5	0 -100 12,5	0 -100 12,5	0 -115 14,5
<b>h10/IT7</b>		0 -48 6	0 -58 7,5	0 -70 9	0 -84 10,5	0 -100 12,5	0 -120 15	0 -120 15	0 -140 17,5	0 -140 17,5	0 -160 20	0 -160 20	0 -160 20	0 -185 23

The cylindricity tolerance (blue numbers) refers to the radius (DIN ISO 1101).  
Double the tolerance values for measuring the shaft diameter.  
For general mechanical engineering, h7 and h8 values are preferable.

200	225	250	280	315	355	400	450	500	560	630	710	800	900	1000	1120	1250
225	250	280	315	355	400	450	500	560	630	710	800	900	1000	1120	1250	

0	0	0	0	0	0	0	0	0	0	0	0	0	0	0	0	0
-30	-30	-35	-35	-40	-40	-45	-45	-50	-50	-75	-75	-100	-100	-125	-125	

+37	+37	+43	+43	+46	+46	+50	+50	+55	+55	+62	+62	+70	+70	+82	+82	
+17	+17	+20	+20	+21	+21	+23	+23	+26	+26	+30	+30	+34	+34	+40	+40	
+46	+46	+52	+52	+57	+57	+63	+63	+70	+70	+80	+80	+90	+90	+106	+106	
+17	+17	+20	+20	+21	+21	+23	+23	+26	+26	+30	+30	+34	+34	+40	+40	
+51	+51	+57	+57	+62	+62	+67	+67	+73	+73	+82	+82	+92	+92	+108	+108	
+31	+31	+34	+34	+37	+37	+40	+40	+44	+44	+50	+50	+56	+56	+66	+66	
+60	+60	+66	+66	+73	+73	+80	+80	+88	+88	+100	+100	+112	+112	+132	+132	
+31	+31	+34	+34	+37	+37	+40	+40	+44	+44	+50	+50	+56	+56	+66	+66	
+79	+79	+88	+88	+98	+98	+108	+108	+122	+122	+138	+138	+156	+156	+186	+186	
+50	+50	+56	+56	+62	+62	+68	+68	+78	+78	+88	+88	+100	+100	+120	+120	
+96	+96	+108	+108	+119	+119	+131	+131	+148	+148	+168	+168	+190	+190	+225	+225	
+50	+50	+56	+56	+62	+62	+68	+68	+78	+78	+88	+88	+100	+100	+120	+120	
+109	+113	+126	+130	+144	+150	+166	+172	+194	+199	+225	+235	+266	+276	+316	+326	
+80	+84	+94	+98	+108	+114	+126	+132	+150	+155	+175	+185	+210	+220	+250	+260	
+126	+130	+146	+150	+165	+171	+189	+195	+220	+225	+255	+265	+300	+310	+355	+365	
+80	+84	+94	+98	+108	+114	+126	+132	+150	+155	+175	+185	+210	+220	+250	+260	
+159	+169	+190	+202	+226	+244	+272	+292	+324	+354	+390	+430	+486	+526	+586	+646	
+130	+140	+158	+170	+190	+208	+232	+252	+280	+310	+340	+380	+430	+470	+520	+580	
+176	+186	+210	+222	+247	+265	+295	+315	+350	+380	+420	+460	+520	+560	+625	+685	
+130	+140	+158	+170	+190	+208	+232	+252	+280	+310	+340	+380	+430	+470	+520	+580	

0	0	0	0	0	0	0	0	0	0	0	0	0	0	0	0	0
-46	-46	-52	-52	-57	-57	-63	-63	-70	-70	-80	-80	-90	-90	-105	-105	
10	10	11,5	11,5	12,5	12,5	13,5	13,5	14,5	14,5	16	16	18	18	21	21	
0	0	0	0	0	0	0	0	0	0	0	0	0	0	0	0	0
-72	-72	-81	-81	-89	-89	-97	-97	-110	-110	-125	-125	-140	-140	-165	-165	
10	10	11,5	11,5	12,5	12,5	13,5	13,5	14,5	14,5	16	16	18	18	21	21	
0	0	0	0	0	0	0	0	0	0	0	0	0	0	0	0	0
-115	-115	-130	-130	-140	-140	-155	-155	-175	-175	-200	-200	-230	-230	-260	-260	
14,5	14,5	16	16	18	18	20	20	22	22	25	25	28	28	33	33	
0	0	0	0	0	0	0	0	0	0	0	0	0	0	0	0	0
-185	-185	-210	-210	-230	-230	-250	-250	-280	-280	-320	-320	-360	-360	-420	-420	
23	23	26	26	28,5	28,5	31,5	31,5	35	35	40	40	45	45	52,5	52,5	

# Tables

## 7.4 Housing Tolerances

Dimensions in mm

Nomin. housing over bore diameter to	<b>6</b> 10	<b>10</b> 18	<b>18</b> 30	<b>30</b> 50	<b>50</b> 65	<b>65</b> 80	<b>80</b> 100	<b>100</b> 120	<b>120</b> 140	<b>140</b> 160	<b>160</b> 180	<b>180</b> 200	<b>200</b> 225
--------------------------------------	----------------	-----------------	-----------------	-----------------	-----------------	-----------------	------------------	-------------------	-------------------	-------------------	-------------------	-------------------	-------------------

Tolerance in microns (normal tolerance)

Bearing outside dia. Deviation $\Delta_{Dmp}$	0 -8	0 -8	0 -9	0 -11	0 -13	0 -13	0 -15	0 -15	0 -18	0 -18	0 -25	0 -30	0 -30
---	---------	---------	---------	----------	----------	----------	----------	----------	----------	----------	----------	----------	----------

Diagram of fit Housing

Bearing

Housing tolerance in microns

<b>D 10</b>	+98 +40	+120 +50	+149 +65	+180 +80	+220 +100	+220 +100	+260 +120	+260 +120	+305 +145	+305 +145	+305 +145	+355 +170	+355 +170
<b>E 8</b>	+47 +25	+59 +32	+73 +40	+89 +50	+106 +60	+106 +60	+126 +72	+126 +72	+148 +85	+148 +85	+148 +85	+172 +100	+172 +100
<b>F 7</b>	+28 +13	+34 +16	+41 +20	+50 +25	+60 +30	+60 +30	+71 +36	+71 +36	+83 +43	+83 +43	+83 +43	+96 +50	+96 +50
<b>G 6</b>	+14 +5	+17 +6	+20 +7	+25 +9	+29 +10	+29 +10	+34 +12	+34 +12	+39 +14	+39 +14	+39 +14	+44 +15	+44 +15
<b>G 7</b>	+20 +5	+24 +6	+28 +7	+34 +9	+40 +10	+40 +10	+47 +12	+47 +12	+54 +14	+54 +14	+54 +14	+61 +15	+61 +15
<b>H 5</b>	+6 0	+8 0	+9 0	+11 0	+13 0	+13 0	+15 0	+15 0	+18 0	+18 0	+18 0	+20 0	+20 0
<b>H 6</b>	+9 0	+11 0	+13 0	+16 0	+19 0	+19 0	+22 0	+22 0	+25 0	+25 0	+25 0	+29 0	+29 0
<b>H 7</b>	+15 0	+18 0	+21 0	+25 0	+30 0	+30 0	+35 0	+35 0	+40 0	+40 0	+40 0	+46 0	+46 0
<b>H 8</b>	+22 0	+27 0	+33 0	+39 0	+46 0	+46 0	+54 0	+54 0	+63 0	+63 0	+63 0	+72 0	+72 0
<b>J 6</b>	+5 -4	+6 -5	+8 -5	+10 -6	+13 -6	+13 -6	+16 -6	+16 -6	+18 -7	+18 -7	+18 -7	+22 -7	+22 -7
<b>J 7</b>	+8 -7	+10 -8	+12 -9	+14 -11	+18 -12	+18 -12	+22 -13	+22 -13	+26 -14	+26 -14	+26 -14	+30 -16	+30 -16
<b>JS 4</b>	+2 -2	+2,5 -2,5	+3 -3	+3,5 -3,5	+4 -4	+4 -4	+5 -5	+5 -5	+6 -6	+6 -6	+6 -6	+7 -7	+7 -7
<b>JS 5</b>	+3 -3	+4 -4	+4,5 -4,5	+5,5 -5,5	+6,5 -6,5	+6,5 -6,5	+7,5 -7,5	+7,5 -7,5	+9 -9	+9 -9	+9 -9	+10 -10	+10 -10
<b>JS 6</b>	+4,5 -4,5	+5,5 -5,5	+6,5 -6,5	+8 -8	+9,5 -9,5	+9,5 -9,5	+11 -11	+11 -11	+12,5 -12,5	+12,5 -12,5	+12,5 -12,5	+14,5 -14,5	+14,5 -14,5
<b>JS 7</b>	+7,5 -7,5	+9 -9	+10,5 -10,5	+12,5 -12,5	+15 -15	+15 -15	+17,5 -17,5	+17,5 -17,5	+20 -20	+20 -20	+20 -20	+23 -23	+23 -23
<b>K 4</b>	+0,5 -3,5	+1 -4	0 -6	+1 -6	+1 -7	+1 -7	+1 -9	+1 -9	+1 -11	+1 -11	+1 -11	0 -14	0 -14
<b>K 5</b>	+1 -5	+2 -6	+1 -8	+2 -9	+3 -10	+3 -10	+2 -13	+2 -13	+3 -15	+3 -15	+3 -15	+2 -18	+2 -18
<b>K 6</b>	+2 -7	+2 -9	+2 -11	+3 -13	+4 -15	+4 -15	+4 -18	+4 -18	+4 -21	+4 -21	+4 -21	+5 -24	+5 -24

<b>225</b>	<b>250</b>	<b>280</b>	<b>315</b>	<b>355</b>	<b>400</b>	<b>450</b>	<b>500</b>	<b>560</b>	<b>630</b>	<b>710</b>	<b>800</b>	<b>900</b>	<b>1000</b>	<b>1120</b>	<b>1250</b>
<b>250</b>	<b>280</b>	<b>315</b>	<b>355</b>	<b>400</b>	<b>450</b>	<b>500</b>	<b>560</b>	<b>630</b>	<b>710</b>	<b>800</b>	<b>900</b>	<b>1000</b>	<b>1120</b>	<b>1250</b>	<b>1400</b>

0	0	0	0	0	0	0	0	0	0	0	0	0	0	0	0
-30	-35	-35	-40	-40	-45	-45	-50	-50	-75	-75	-100	-100	-125	-125	-160

+355	+400	+400	+440	+440	+480	+480	+540	+540	+610	+610	+680	+680	+770	+770	+890
+170	+190	+190	+210	+210	+230	+230	+260	+260	+290	+290	+320	+320	+350	+350	+390
+172	+191	+191	+214	+214	+232	+232	+255	+255	+285	+285	+310	+310	+360	+360	+415
+100	+110	+110	+125	+125	+135	+135	+145	+145	+160	+160	+170	+170	+195	+195	+220
+96	+108	+108	+119	+119	+131	+131	+144	+144	+160	+160	+176	+176	+203	+203	+235
+50	+56	+56	+62	+62	+68	+68	+76	+76	+80	+80	+86	+86	+98	+98	+110
+44	+49	+49	+54	+54	+60	+60	+66	+66	+74	+74	+82	+82	+94	+94	+108
+15	+17	+17	+18	+18	+20	+20	+22	+22	+24	+24	+26	+26	+28	+28	+30
+61	+69	+69	+75	+75	+83	+83	+92	+92	+104	+104	+116	+116	+133	+133	+155
+15	+17	+17	+18	+18	+20	+20	+22	+22	+24	+24	+26	+26	+28	+28	+30
+20	+23	+23	+25	+25	+27	+27									
0	0	0	0	0	0	0									
+29	+32	+32	+36	+36	+40	+40	+44	+44	+50	+50	+56	+56	+66	+66	+78
0	0	0	0	0	0	0	0	0	0	0	0	0	0	0	0
+46	+52	+52	+57	+57	+63	+63	+70	+70	+80	+80	+90	+90	+105	+105	+125
0	0	0	0	0	0	0	0	0	0	0	0	0	0	0	0
+72	+81	+81	+89	+89	+97	+97	+110	+110	+125	+125	+140	+140	+165	+165	+195
0	0	0	0	0	0	0	0	0	0	0	0	0	0	0	0
+22	+25	+25	+29	+29	+33	+33									
-7	-7	-7	-7	-7	-7	-7									
+30	+36	+36	+39	+39	+43	+43									
-16	-16	-16	-18	-18	-20	-20									
+7	+8	+8	+9	+9	+10	+10									
-7	-8	-8	-9	-9	-10	-10									
+10	+11,5	+11,5	+12,5	+12,5	+13,5	+13,5									
-10	-11,5	-11,5	-12,5	-12,5	-13,5	-13,5									
+14,5	+16	+16	+18	+18	+20	+20	+22	+22	+25	+25	+28	+28	+33	+33	+39
-14,5	-16	-16	-18	-18	-20	-20	-22	-22	-25	-25	-28	-28	-33	-33	-39
+23	+26	+26	+28,5	+28,5	+31,5	+31,5	+35	+35	+40	+40	+45	+45	+52	+52	+62
-23	-26	-26	-28,5	-28,5	-31,5	-31,5	-35	-35	-40	-40	-45	-45	-52	-52	-62
0	0	0	0	0	0	0									
-14	-16	-16	-17	-17	-20	-20									
+2	+3	+3	+3	+3	+2	+2									
-18	-20	-20	-22	-22	-25	-25									
+5	+5	+5	+7	+7	+8	+8	0	0	0	0	0	0	0	0	0
-24	-27	-27	-29	-29	-32	-32	-44	-44	-50	-50	-56	-56	-66	-66	-78

# Tables

## 7.4 Housing Tolerances (continuation)

Dimensions in mm

Nomin. housing over bore diameter to	6	10	18	30	50	65	80	100	120	140	160	180	200	225
	10	18	30	50	65	80	100	120	140	160	180	200	225	

Tolerance in microns (normal tolerance)

Bearing outside dia. Deviation $\Delta_{Dmp}$	0	0	0	0	0	0	0	0	0	0	0	0	0	0
	-8	-8	-9	-11	-13	-13	-15	-15	-18	-18	-25	-30	-30	-30

Diagram of fit  
Housing Bearing

Housing tolerance in microns

<b>K 7</b>		+5 -10	+6 -12	+6 -15	+7 -18	+9 -21	+9 -21	+10 -25	+10 -25	+12 -28	+12 -28	+12 -28	+13 -33	+13 -33
<b>M 6</b>		-3 -12	-4 -15	-4 -17	-4 -20	-5 -24	-5 -24	-6 -28	-6 -28	-8 -33	-8 -33	-8 -33	-8 -37	-8 -37
<b>M 7</b>		0 -15	0 -18	0 -21	0 -25	0 -30	0 -30	0 -35	0 -35	0 -40	0 -40	0 -40	0 -46	0 -46
<b>N 6</b>		-7 -16	-9 -20	-11 -24	-12 -28	-14 -33	-14 -33	-16 -38	-16 -38	-20 -45	-20 -45	-20 -45	-22 -51	-22 -51
<b>N 7</b>		-4 -19	-5 -23	-7 -28	-8 -33	-9 -39	-9 -39	-10 -45	-10 -45	-12 -52	-12 -52	-12 -52	-14 -60	-14 -60
<b>P 6</b>		-12 -21	-15 -26	-18 -31	-21 -37	-26 -45	-26 -45	-30 -52	-30 -52	-36 -61	-36 -61	-36 -61	-41 -70	-41 -70
<b>P 7</b>		-9 -24	-11 -29	-14 -35	-17 -42	-21 -51	-21 -51	-24 -59	-24 -59	-28 -68	-28 -68	-28 -68	-33 -79	-33 -79
<b>R 6</b>		-16 -25	-20 -31	-24 -37	-29 -45	-35 -54	-37 -56	-44 -66	-47 -69	-56 -81	-58 -83	-61 -86	-68 -97	-71 -100
<b>S 6</b>		-20 -29	-25 -36	-31 -44	-38 -54	-47 -66	-53 -72	-64 -86	-72 -94	-85 -110	-93 -118	-101 -126	-113 -142	-121 -150

225	250	280	315	355	400	450	500	560	630	710	800	900	1000	1120	1250
250	280	315	355	400	450	500	560	630	710	800	900	1000	1120	1250	1400

0	0	0	0	0	0	0	0	0	0	0	0	0	0	0	0
-30	-35	-35	-40	-40	-45	-45	-50	-50	-75	-75	-100	-100	-125	-125	-160

+13	+16	+16	+17	+17	+18	+18	0	0	0	0	0	0	0	0	0
-33	-36	-36	-40	-40	-45	-45	-70	-70	-80	-80	-90	-90	-105	-105	-125
-8	-9	-9	-10	-10	-10	-10	-26	-26	-30	-30	-34	-34	-40	-40	-48
-37	-41	-41	-46	-46	-50	-50	-70	-70	-80	-80	-90	-90	-106	-106	-126
0	0	0	0	0	0	0									
-46	-52	-52	-57	-57	-63	-63									
-22	-25	-25	-26	-26	-27	-27	-44	-44	-50	-50	-56	-56	-66	-66	-78
-51	-57	-57	-62	-62	-67	-67	-88	-88	-100	-100	-112	-112	-132	-132	-156
-14	-14	-14	-16	-16	-17	-17									
-60	-66	-66	-73	-73	-80	-80									
-41	-47	-47	-51	-51	-55	-55	-78	-78	-88	-88	-100	-100	-120	-120	-140
-70	-79	-79	-87	-87	-95	-95	-122	-122	-138	-138	-156	-156	-186	-186	-218
-33	-36	-36	-41	-41	-45	-45	-78	-78	-88	-88	-100	-100	-120	-120	-140
-79	-88	-88	-98	-98	-108	-108	-148	-148	-168	-168	-190	-190	-225	-225	-265
-75	-85	-89	-97	-103	-113	-119	-150	-155	-175	-185	-210	-220	-250	-260	-300
-104	-117	-121	-133	-139	-153	-159	-194	-199	-225	-235	-266	-276	-316	-326	-378
-131	-149	-161	-179	-197	-219	-239									
-160	-181	-193	-215	-233	-259	-279									

# Tables

## 7.5 Normal Tolerances of FAG Radial Bearings (Except Tapered Roller Bearings)

### Inner ring

Dimensions in mm

Nominal bore diameter d	over to	2,5 10	10 18	18 30	30 50	50 80	80 120	120 180	180 250	250 315	315 400	400 500	500 630	630 800	800 1000	1000 1250
-------------------------	---------	-----------	----------	----------	----------	----------	-----------	------------	------------	------------	------------	------------	------------	------------	-------------	--------------

### Tolerance class PN (normal tolerance)

Tolerance in microns

Bore, cylindrical Deviation $\Delta_{dmp}$	0 -8	0 -8	0 -10	0 -12	0 -15	0 -20	0 -25	0 -30	0 -35	0 -40	0 -45	0 -50	0 -75	0 -100	0 -125	
Variation $V_{dp}$	diameter series 7 · 8 · 9															
	10	10	13	15	19	25	31	38	44	50	56	63				
	0 · 1	8	8	10	12	19	25	31	38	44	50	56	63			
	2 · 3 · 4	6	6	8	9	11	15	19	23	26	30	34	38			
Variation $V_{dmp}$	6	6	8	9	11	15	19	23	26	30	34	38				
Bore, taper 1:12 Deviation $\Delta_{dmp}$	+15 0	+18 0	+21 0	+25 0	+30 0	+35 0	+40 0	+46 0	+52 0	+57 0	+63 0	+70 0	+80 0	+90 0	+105 0	
Deviation $\Delta_{d1mp} - \Delta_{dmp}$	+15 0	+18 0	+21 0	+25 0	+30 0	+35 0	+40 0	+46 0	+52 0	+57 0	+63 0	+70 0	+80 0	+90 0	+105 0	
Variation $V_{dp}$	10	10	13	15	19	25	31	38	44	50	56					
Bore, taper 1:30 Deviation $\Delta_{dmp}$					+15 0	+20 0	+25 0	+30 0	+35 0	+40 0	+45 0	+50 0	+75 0	+100 0	+125 0	
Deviation $\Delta_{d1mp} - \Delta_{dmp}$					+35 0	+40 0	+50 0	+55 0	+60 0	+65 0	+75 0	+85 0	+100 0	+100 0	+115 0	
Variation $V_{dp}$					19	25	31	38	44	50	56	63				
Width deviation $\Delta_{Bs}$	0 -120	0 -120	0 -120	0 -120	0 -150	0 -200	0 -250	0 -300	0 -350	0 -400	0 -450	0 -500	0 -750	0 -1000	0 -1250	
Width variation $V_{Bs}$	15	20	20	20	25	25	30	30	35	40	50	60	70	80	100	
Radial runout $K_{ia}$	10	10	13	15	20	25	30	40	50	60	65	70	80	90	100	

### Bore diameter

- $\Delta_{dmp}$  Single plane mean bore diameter deviation
- $\Delta_{d1mp}$  Deviation of mean large diameter from nominal dimension (tapered bore)
- $V_{dp}$  Bore diameter variation in a single radial plane
- $V_{dmp}$  Mean bore diameter variation; difference between maximum and minimum mean bore diameter

### Outside diameter

- $\Delta_{Dmp}$  Single plane mean outside diameter deviation
- $V_{Dp}$  Outside diameter variation in a single radial plane
- $V_{Dmp}$  Mean outside diameter variation; difference between maximum and minimum mean outside diameter

## Outer ring

Nominal outside diameter D	over to	Dimensions in mm															
		6 18	18 30	30 50	50 80	80 120	120 150	150 180	180 250	250 315	315 400	400 500	500 630	630 800	800 1000	1000 1250	1250 1600

## Tolerance class PN (normal tolerance)

		Tolerance in microns															
Deviation	$\Delta_{Dmp}$	0 -8	0 -9	0 -11	0 -13	0 -15	0 -18	0 -25	0 -30	0 -35	0 -40	0 -45	0 -50	0 -75	0 -100	0 -125	0 -160
Variation $V_{Dp}$	diameter series 7-8-9	10	12	14	16	19	23	31	38	44	50	56	63	94	125		
	0-1	8	9	11	13	19	23	31	38	44	50	56	63	94	125		
	2-3-4	6	7	8	10	11	14	19	23	26	30	34	38	55	75		
	sealed bear- ings 2-3-4	10	12	16	20	26	30	38									
Variation	$V_{Dmp}$	6	7	8	10	11	14	19	23	26	30	34	38	55	75		
Radial runout	$K_{ea}$	15	15	20	25	35	40	45	50	60	70	80	100	120	140	160	190

The width tolerances  $\Delta_{Cs}$  and  $V_{Cs}$  are identical to  $\Delta_{Bs}$  and  $V_{Bs}$  for the pertinent inner ring.

## Width

$\Delta_B, \Delta_{Cs}$  Deviation of a single ring width (inner and outer ring) from nominal dimension

$V_{Bs}, V_{Cs}$  Variation of inner ring width and outer ring width

## Running accuracy

$K_{ia}$  Radial runout of assembled bearing inner ring

$K_{ea}$  Radial runout of assembled bearing outer ring

# Tables

## 7.6 Normal Tolerances of FAG Tapered Roller Bearings in Metric Dimensions

### Cone

Dimensions in mm

Nominal bore diameter d	over to	10	18	30	50	80	120	180	250	315	400	500
		18	30	50	80	120	180	250	315	400	500	630

### Tolerance class PN (normal tolerance)

Tolerance in microns

Deviation	$\Delta_{dmp}$	0	0	0	0	0	0	0	0	0	0	0
		-12	-12	-12	-15	-20	-25	-30	-35	-40	-45	-50
Variation	$V_{dp}$	12	12	12	15	20	25	30	35	40	45	50
	$V_{dmp}$	9	9	9	11	15	19	23	26	30		
Width deviation	$\Delta_{Bs}$	0	0	0	0	0	0	0	0	0	0	0
		-120	-120	-120	-150	-200	-250	-300	-350	-400	-450	-500
Radial runout	$K_{ia}$	15	18	20	25	30	35	50	60	70	70	85
Width deviation	$\Delta_{Ts}$	+200	+200	+200	+200	+200	+350	+350	+350	+400	+400	+500
		0	0	0	0	-200	-250	-250	-250	-400	-400	-500
	$\Delta_{T1s}$	+100	+100	+100	+100	+100	+150	+150	+150	+200		
		0	0	0	0	-100	-150	-150	-150	-200		
	$\Delta_{T2s}$	+100	+100	+100	+100	+100	+200	+200	+200	+200		
		0	0	0	0	-100	-100	-100	-100	-200		

### Cup

Dimensions in mm

Nominal outside diameter D	over to	18	30	50	80	120	150	180	250	315	400	500	630	800
		30	50	80	120	150	180	250	315	400	500	630	800	1000

### Tolerance class PN (normal tolerance)

Tolerance in microns

Deviation	$\Delta_{Dmp}$	0	0	0	0	0	0	0	0	0	0	0	0	
		-12	-14	-16	-18	-20	-25	-30	-35	-40	-45	-50	-75	-100
Variation	$V_{Dp}$	12	14	16	18	20	25	30	35	40	45	50	75	100
	$V_{Dmp}$	9	11	12	14	15	19	23	26	30	34	38		
Radial runout	$K_{ea}$	18	20	25	35	40	45	50	60	70	80	100	120	120

The width tolerance  $\Delta_{Cs}$  is identical with  $\Delta_{Bs}$  for the pertinent inner ring.

- $T_s$  Overall width of a tapered roller bearing, measured at a single position
- $T_{1s}$  Overall width of a tapered roller bearing, measured at a single position by cone and master cup
- $T_{2s}$  Overall width of a tapered roller bearing, measured at a single position by cup and master cone
- $\Delta_{Ts} = T_s - T$ ,  $\Delta_{T1s} = T_{1s} - T_1$ ,  $\Delta_{T2s} = T_{2s} - T_2$  Deviation of a single tapered roller bearing overall width from nominal dimension
- $H_s, H_{1s}, H_{2s}, H_{3s}, H_{4s}$  Overall thrust bearing height measured at a single position
- $\Delta_{Hs} = H_s - H$ ,  $\Delta_{H1s} = H_{1s} - H_1$ ,  $\Delta_{H2s} = H_{2s} - H_2, \dots$  Deviation of a single overall thrust bearing height from nominal dimension
- H Overall height of a single direction thrust bearing
- $H_1$  Overall height of a single direction thrust bearing with seating ring
- $H_2$  Overall height of a double direction thrust bearing
- $H_3$  Overall height of a double direction thrust bearing with seating rings
- $H_4$  Overall height of a spherical roller thrust bearing

## 7.7 Normal Tolerances of FAG Thrust Bearings

### Shaft washer

Dimensions in mm

Nominal bore diameter $d_w$	over to	18	18 30	30 50	50 80	80 120	120 180	180 250	250 315	315 400	400 500	500 630	630 800	800 1000	1000 1250
-----------------------------	---------	----	----------	----------	----------	-----------	------------	------------	------------	------------	------------	------------	------------	-------------	--------------

### Tolerance class PN (normal tolerance)

Tolerance in microns

Deviation $\Delta_{dmp}$		0 -8	0 -10	0 -12	0 -15	0 -20	0 -25	0 -30	0 -35	0 -40	0 -45	0 -50	0 -75	0 -100	0 -125
Variation $V_{dp}$		6	8	9	11	15	19	23	26	30	34	38			
Wall thickness variation $S_{Tj}$		10	10	10	10	15	15	20	25	30	30	35	40	45	50
Seating ring deviation $\Delta_{du}$		+70 0	+70 0	+85 0	+100 0	+120 0	+140 0	+140 0	+160 0	+180 0	+180 0				

### Housing washer

Dimensions in mm

Nominal outside diameter $D_g$	over to	18 30	30 50	50 80	80 120	120 180	180 250	250 315	315 400	400 500	500 630	630 800	800 1000	1000 1250	1250 1600
--------------------------------	---------	----------	----------	----------	-----------	------------	------------	------------	------------	------------	------------	------------	-------------	--------------	--------------

### Tolerance class PN (normal tolerance)

Tolerance in microns

Deviation $\Delta_{Dmp}$		0 -13	0 -16	0 -19	0 -22	0 -25	0 -30	0 -35	0 -40	0 -45	0 -50	0 -75	0 -100	0 -125	0 -160
Variation $V_{Dp}$		10	12	14	17	19	23	26	30	34	38	55	75		
Seating ring deviation $\Delta_{Du}$		0 -30	0 -35	0 -45	0 -60	0 -75	0 -90	0 -105	0 -120	0 -135	0 -180				

\*) The values of the wall thickness variation apply to shaft and housing washers

### Construction Heights of Thrust Bearings

Dimensions in mm

Nominal bore diameter $d_w$	over to	30	30 50	50 80	80 120	120 180	180 250	250 315	315 400	400 500	500 630	630 800	800 1000	1000 1250
-----------------------------	---------	----	----------	----------	-----------	------------	------------	------------	------------	------------	------------	------------	-------------	--------------

### Tolerance classes PN ... P4

Tolerance in microns

Deviation $\Delta_{Hs}$		+20 -250	+20 -250	+20 -300	+25 -300	+25 -400	+30 -400	+40 -400	+40 -500	+50 -500	+60 -600	+70 -750	+80 -1000	+100 -1400
$\Delta_{H1s}$		+100 -250	+100 -250	+100 -300	+150 -300	+150 -400	+150 -400	+200 -400	+200 -500	+300 -500	+350 -600	+400 -750	+450 -1000	+500 -1400
$\Delta_{H2s}$		+150 -400	+150 -400	+150 -500	+200 -500	+200 -600	+250 -600	+350 -700	+350 -700	+400 -900	+500 -1100	+600 -1300	+700 -1500	+900 -1800
$\Delta_{H3s}$		+300 -400	+300 -400	+300 -500	+400 -500	+400 -600	+500 -600	+600 -700	+600 -700	+750 -900	+900 -1100	+1100 -1300	+1300 -1500	+1600 -1800
$\Delta_{H4s}$		+20 -300	+20 -300	+20 -400	+25 -400	+25 -500	+30 -500	+40 -700	+40 -700	+50 -900	+60 -1200	+70 -1400	+80 -1800	+100 -2400

# Tables

## 7.8 Limit Dimensions of Chamfer

### Symbols

$r_{1s}, r_{3s}$	chamfer in radial direction
$r_{2s}, r_{4s}$	chamfer in axial direction
$r_{smin}$	general symbol for the minimum chamfer $r_{1smin}, r_{2smin}, r_{3smin}, r_{4smin}$
$r_{1smax}, r_{3smax}$	maximum chamfer in radial direction
$r_{2smax}, r_{4smax}$	maximum chamfer in axial direction

### Chamfer of radial bearings (except tapered roller bearings)

		Dimensions in mm												
		0,1	0,15	0,2	0,3	0,6		1		1,1		1,5		
$r_{smin}$														
Nominal bore diameter d	over to				40	40	40	40	50	50	120	120	120	
$r_{1smax}$		0,2	0,3	0,5	0,6	0,8	1	1,3	1,5	1,9	2	2,5	2,3	3
$r_{2smax}$		0,4	0,6	0,8	1	1	2	2	3	3	3,5	4	4	5

### Chamfer of tapered roller bearings in metric dimensions Cone

		Dimensions in mm											
		0,3		0,6		1		1,5		2			
$r_{smin}$													
Nominal bore diameter d	over to	40	40	40	40	50	50	120	250	250	120	250	250
$r_{1smax}$		0,7	0,9	1,1	1,3	1,6	1,9	2,3	2,8	3,5	2,8	3,5	4
$r_{2smax}$		1,4	1,6	1,7	2	2,5	3	3	3,5	4	4	4,5	5

### Cup

		Dimensions in mm											
		0,3		0,6		1		1,5		2			
$r_{smin}$													
Nominal outside diameter D	over to	40	40	40	40	50	50	120	250	250	120	250	250
$r_{3smax}$		0,7	0,9	1,1	1,3	1,6	1,9	2,3	2,8	3,5	2,8	3,5	4
$r_{4smax}$		1,4	1,6	1,7	2	2,5	3	3	3,5	4	4	4,5	5

### Chamfer of thrust bearings

		Dimensions in mm																		
		0,1	0,15	0,2	0,3	0,6	1	1,1	1,5	2	2,1	3	4	5	6	7,5	9,5	12	15	19
$r_{smin}$																				
$r_{1smax}, r_{2smax}$		0,2	0,3	0,5	0,8	1,5	2,2	2,7	3,5	4	4,5	5,5	6,5	8	10	12,5	15	18	21	25

## Radial bearings

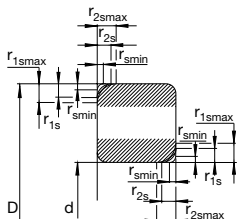

## Tapered roller bearings

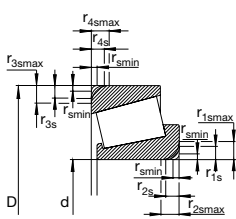

## Thrust bearings

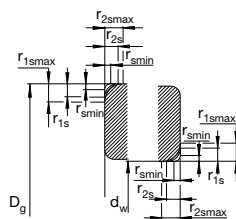

	2		2,1		2,5		3		4	5	6	7,5	9,5	12	15	19		
	80	80 220	220	280	280	100	100 280	280	280									
	3	3,5	3,8	4	4,5	3,8	4,5	5	5	5,5	6,5	8	10	12,5	15	18	21	25
	4,5	5	6	6,5	7	6	6	7	8	8	9	10	13	17	19	24	30	38

	2,5		3		4		5		6						
	120	120 250	250	120	120 250	250	400	120	120 250	250	400	180	180	180	180
	3,5	4	4,5	4	4,5	5	5,5	5	5,5	6	6,5	6,5	7,5	7,5	9
	5	5,5	6	5,5	6,5	7	7,5	7	7,5	8	8,5	8	9	10	11

	2,5		3		4		5		6						
	120	120 250	250	120	120 250	250	400	120	120 250	250	400	180	180	180	180
	3,5	4	4,5	4	4,5	5	5,5	5	5,5	6	6,5	6,5	7,5	7,5	9
	5	5,5	6	5,5	6,5	7	7,5	7	7,5	8	8,5	8	9	10	11

# Tables

## 7.9 Radial Clearance of FAG Deep Groove Ball Bearings

Dimensions in mm

Nominal bore diameter	over to	<b>2,5</b> <b>6</b>	<b>6</b> <b>10</b>	<b>10</b> <b>18</b>	<b>18</b> <b>24</b>	<b>24</b> <b>30</b>	<b>30</b> <b>40</b>	<b>40</b> <b>50</b>	<b>50</b> <b>65</b>	<b>65</b> <b>80</b>	<b>80</b> <b>100</b>	<b>100</b> <b>120</b>	<b>120</b> <b>140</b>	<b>140</b> <b>160</b>	<b>160</b> <b>180</b>	<b>180</b> <b>200</b>
-----------------------	---------	------------------------	-----------------------	------------------------	------------------------	------------------------	------------------------	------------------------	------------------------	------------------------	-------------------------	--------------------------	--------------------------	--------------------------	--------------------------	--------------------------

Bearing clearance in microns

Clearance group C2	min max	0 7	0 7	0 9	0 10	1 11	1 11	1 15	1 15	1 18	2 20	2 23	2 23	2 25	2 30	
Clearance group CN (norm.)	min max	2 13	2 13	3 18	5 20	5 20	6 20	6 23	8 28	10 30	12 36	15 41	18 48	18 53	20 61	25 71
Clearance group C3	min max	8 23	8 23	11 25	13 28	13 28	15 33	18 36	23 43	25 51	30 58	36 66	41 81	46 91	53 102	63 117
Clearance group C4	min max		14 29	18 33	20 36	23 41	28 46	30 51	38 61	46 71	53 84	61 97	71 114	81 130	91 147	107 163

Dimensions in mm

Nominal bore diameter	over to	<b>200</b> <b>225</b>	<b>225</b> <b>250</b>	<b>250</b> <b>280</b>	<b>280</b> <b>315</b>	<b>315</b> <b>355</b>	<b>355</b> <b>400</b>	<b>400</b> <b>450</b>	<b>450</b> <b>500</b>	<b>500</b> <b>560</b>	<b>560</b> <b>630</b>	<b>630</b> <b>710</b>	<b>710</b> <b>800</b>	<b>800</b> <b>900</b>	<b>900</b> <b>1000</b>	<b>1000</b> <b>1120</b>	<b>1120</b> <b>1250</b>
-----------------------	---------	--------------------------	--------------------------	--------------------------	--------------------------	--------------------------	--------------------------	--------------------------	--------------------------	--------------------------	--------------------------	--------------------------	--------------------------	--------------------------	---------------------------	----------------------------	----------------------------

Bearing clearance in microns

Clearance group C2	min max	4 32	4 36	4 39	8 45	8 50	8 60	10 70	10 80	20 90	20 100	30 120	30 130	30 150	40 160	40 170	40 180
Clearance group CN (norm.)	min max	28 82	31 92	36 97	42 110	50 120	60 140	70 160	80 180	90 200	100 220	120 250	130 280	150 310	160 340	170 370	180 400
Clearance group C3	min max	73 132	87 152	97 162	110 180	120 200	140 230	160 260	180 290	200 320	220 350	250 390	280 440	310 490	340 540	370 590	400 640
Clearance group C4	min max	120 187	140 217	152 237	175 260	200 290	230 330	260 370	290 410	320 460	350 510	390 560	440 620	490 690	540 760	590 840	640 910

## 7.10 Radial Clearance of FAG Self-Aligning Ball Bearings

Dimensions in mm

Nominal bore diameter	over to	<b>2,5</b> <b>6</b>	<b>6</b> <b>10</b>	<b>10</b> <b>14</b>	<b>14</b> <b>18</b>	<b>18</b> <b>24</b>	<b>24</b> <b>30</b>	<b>30</b> <b>40</b>	<b>40</b> <b>50</b>	<b>50</b> <b>65</b>	<b>65</b> <b>80</b>	<b>80</b> <b>100</b>	<b>100</b> <b>120</b>	<b>120</b> <b>140</b>	<b>140</b> <b>160</b>
-----------------------	---------	------------------------	-----------------------	------------------------	------------------------	------------------------	------------------------	------------------------	------------------------	------------------------	------------------------	-------------------------	--------------------------	--------------------------	--------------------------

### with cylindrical bore

Bearing clearance in microns

Clearance group C2	min	1	2	2	3	4	5	6	6	7	8	9	10	10	15
	max	8	9	10	12	14	16	18	19	21	24	27	31	38	44
Clearance group CN (norm.)	min	5	6	6	8	19	11	13	14	16	18	22	25	30	35
	max	15	17	19	21	23	24	29	31	36	40	48	56	68	80
Clearance group C3	min	10	12	13	15	17	19	23	25	30	35	42	50	60	70
	max	20	25	26	28	30	35	40	44	50	60	70	83	100	120
Clearance group C4	min	15	19	21	23	25	29	34	37	45	54	64	75	90	110
	max	25	33	35	37	39	46	53	57	69	83	96	114	135	161

### with tapered bore

Bearing clearance in microns

Clearance group C2	min					7	9	12	14	18	23	29	35	40	45
	max					17	20	24	27	32	39	47	56	68	74
Clearance group CN (norm.)	min					13	15	19	22	27	35	42	50	60	65
	max					26	28	35	39	47	57	68	81	98	110
Clearance group C3	min					20	23	29	33	41	50	62	75	90	100
	max					33	39	46	52	61	75	90	108	130	150
Clearance group C4	min					28	33	40	45	56	69	84	100	120	140
	max					42	50	59	65	80	98	116	139	165	191

# Tables

## 7.11 Radial Clearance of FAG Cylindrical Roller Bearings

Dimensions in mm

Nominal bore diameter	over to	24	24 30	30 40	40 50	50 65	65 80	80 100	100 120	120 140	140 160	160 180	180 200	200 225	225 250
-----------------------	---------	----	----------	----------	----------	----------	----------	-----------	------------	------------	------------	------------	------------	------------	------------

### with cylindrical bore

Bearing clearance in microns

Clearance group C1NA <sup>1)</sup>	min	5	5	5	5	5	10	10	10	10	10	10	15	15	15
	max	15	15	15	18	20	25	30	30	35	35	40	45	50	50
Clearance group C2	min	0	0	5	5	10	10	15	15	15	20	25	35	45	45
	max	25	25	30	35	40	45	50	55	60	70	75	90	105	110
Clearance group CN (norm.)	min	20	20	25	30	40	40	50	50	60	70	75	90	105	110
	max	45	45	50	60	70	75	85	90	105	120	125	145	165	175
Clearance group C3	min	35	35	45	50	60	65	75	85	100	115	120	140	160	170
	max	60	60	70	80	90	100	110	125	145	165	170	195	220	235
Clearance group C4	min	50	50	60	70	80	90	105	125	145	165	170	195	220	235
	max	75	75	85	100	110	125	140	165	190	215	220	250	280	300

### with tapered bore

Bearing clearance in microns

Clearance group C1NA <sup>1)</sup>	min	10	15	15	17	20	25	35	40	45	50	55	60	60	65
	max	20	25	25	30	35	40	55	60	70	75	85	90	95	100
Clearance group C2	min	15	20	20	25	30	35	40	50	55	60	75	85	95	105
	max	40	45	45	55	60	70	75	90	100	110	125	140	155	170
Clearance group CN (norm.)	min	30	35	40	45	50	60	70	90	100	110	125	140	155	170
	max	55	60	65	75	80	95	105	130	145	160	175	195	215	235
Clearance group C3	min	40	45	55	60	70	85	95	115	130	145	160	180	200	220
	max	65	70	80	90	100	120	130	155	175	195	210	235	260	285
Clearance group C4	min	50	55	70	75	90	110	120	140	160	180	195	220	245	270
	max	75	80	95	105	120	145	155	180	205	230	245	275	305	335

250	280	315	355	400	450	500	560	630	710	800	900	1000	1120	1250	1400	1600	1800	2000
280	315	355	400	450	500	560	630	710	800	900	1000	1120	1250	1400	1600	1800	2000	

20	20	20	25	25	25	25	30	30	35	35	35	50	60	60	70	80	100
55	60	65	75	85	95	100	110	130	140	160	180	200	220	240	270	300	320
55	65	100	110	110	120	140	145	150	180	200	220	230	270	330	380	400	
125	130	145	190	210	220	240	260	285	310	350	390	430	470	530	610	760	
195	205	225	280	310	330	360	380	425	470	520	580	640	710	790	890	1120	
190	200	225	280	310	330	360	380	425	470	520	580	640	710	790	890	1120	
260	275	305	370	410	440	480	500	565	630	690	770	850	950	1050	1170	1480	
260	275	305	370	410	440	480	500	565	630	690	770	850	950	1050	1170	1480	
330	350	385	460	510	550	600	620	705	790	860	960	1060	1190	1310	1450	1840	

75	80	90	100	110	120	130	140	160	170	190	210	230	250	270	300	320	340
110	120	135	150	170	190	210	230	260	290	330	360	400	440	460	500	530	560
115	130	145	165	185	205	230	260	295	325	370	410	455	490	550	640	760	
185	205	225	255	285	315	350	380	435	485	540	600	665	730	810	920	1120	
185	205	225	255	285	315	350	380	435	485	540	600	665	730	810	920	1120	
255	280	305	345	385	425	470	500	575	645	710	790	875	970	1070	1200	1480	
240	265	290	330	370	410	455	500	565	630	700	780	865	960	1070	1200	1480	
310	340	370	420	470	520	575	620	705	790	870	970	1075	1200	1330	1480	1840	
295	325	355	405	455	505	560	620	695	775	860	960	1065	1200	1330	1480	1840	
365	400	435	495	555	615	680	740	835	935	1030	1150	1275	1440	1590	1760	2200	

1) Clearance group C1NA applies to single and double row cylindrical roller bearings of tolerance classes SP and UP.

# Tables

## 7.12 Radial Clearance of FAG Spherical Roller Bearings

Dimensions in mm

Nominal bore diameter	over to	24	30	40	50	65	80	100	120	140	160	180	200	225	250
-----------------------	---------	----	----	----	----	----	----	-----	-----	-----	-----	-----	-----	-----	-----

### with cylindrical bore

Bearing clearance in microns

Clearance group C2	min	10	15	15	20	20	30	35	40	50	60	65	70	80	90
	max	20	25	30	35	40	50	60	75	95	110	120	130	140	150
Clearance group CN (norm.)	min	20	25	30	35	40	50	60	75	95	110	120	130	140	150
	max	35	40	45	55	65	80	100	120	145	170	180	200	220	240
Clearance group C3	min	35	40	45	55	65	80	100	120	145	170	180	200	220	240
	max	45	55	60	75	90	110	135	160	190	220	240	260	290	320
Clearance group C4	min	45	55	60	75	90	110	135	160	190	220	240	260	290	320
	max	60	75	80	100	120	145	180	210	240	280	310	340	380	420

### with tapered bore

Bearing clearance in microns

Clearance group C2	min	15	20	25	30	40	50	55	65	80	90	100	110	120	140
	max	25	30	35	45	55	70	80	100	120	130	140	160	180	200
Clearance group CN (norm.)	min	25	30	35	45	55	70	80	100	120	130	140	160	180	200
	max	35	40	50	60	75	95	110	130	160	180	200	220	250	270
Clearance group C3	min	35	40	50	60	75	95	110	135	160	180	200	220	250	270
	max	45	55	65	80	95	120	140	170	200	230	260	290	320	350
Clearance group C4	min	45	55	65	80	95	120	140	170	200	230	260	290	320	350
	max	60	75	85	100	120	150	180	220	260	300	340	370	410	450

250	280	315	355	400	450	500	560	630	710	800	900	1000	1120	1250	1400
280	315	355	400	450	500	560	630	710	800	900	1000	1120	1250	1400	1600

100	110	120	130	140	140	150	170	190	210	230	260	290	320	350	380
170	190	200	220	240	260	180	310	350	390	430	480	530	580	630	700
170	190	200	220	240	260	180	310	350	390	430	480	530	580	630	700
260	280	310	340	370	410	440	480	530	580	650	710	770	840	910	1020
350	370	410	450	500	550	600	650	700	770	860	930	1050	1140	1240	1390
350	370	410	450	500	550	600	650	700	770	860	930	1050	1140	1240	1390
460	500	550	600	660	720	780	850	920	1010	1120	1220	1430	1560	1700	1890

150	170	190	210	230	260	290	320	350	390	440	490	540	600	660	740
220	240	270	300	330	370	410	460	510	570	640	710	780	860	940	1060
220	240	270	300	330	370	410	460	510	570	640	710	780	860	940	1060
300	330	360	400	440	490	540	600	670	750	840	930	1020	1120	1220	1380
390	430	470	520	570	630	680	760	850	960	1070	1190	1300	1420	1550	1750
390	430	470	520	570	630	680	760	850	960	1070	1190	1300	1420	1550	1750
490	540	590	650	720	790	870	980	1090	1220	1370	1520	1650	1800	1960	2200

# Tables

## 7.13 Radial Clearance of FAG Barrel Roller Bearings

Dimensions in mm

Nominal bore diameter	over to	Dimensions in mm														
		30	30 40	40 50	50 65	65 80	80 100	100 120	120 140	140 160	160 180	180 225	225 250	250 280	280 315	315 355

### with cylindrical bore

Bearing clearance in microns

Clearance group	min max	Bearing clearance in microns														
		2 9	3 10	3 13	4 15	5 20	7 25	10 30	15 35	20 40	25 45	30 50	35 55	40 60	40 70	45 75
Clearance group C2		2 9	3 10	3 13	4 15	5 20	7 25	10 30	15 35	20 40	25 45	30 50	35 55	40 60	40 70	45 75
Clearance group CN (norm.)		9 17	10 20	13 23	15 27	20 35	25 45	30 50	35 55	40 65	45 70	50 75	55 80	60 85	70 100	75 105
Clearance group C3		17 28	20 30	23 35	27 40	35 55	45 65	50 70	55 80	65 95	70 100	75 105	80 110	85 115	100 135	105 140
Clearance group C4		28 40	30 45	35 50	40 55	55 75	65 90	70 95	80 110	95 125	100 130	105 135	110 140	115 145	135 170	140 175

### with tapered bore

Bearing clearance in microns

Clearance group	min max	Bearing clearance in microns														
		9 17	10 20	13 23	15 27	20 35	25 45	30 50	35 55	40 65	45 70	50 75	55 80	60 85	70 100	75 105
Clearance group C2		9 17	10 20	13 23	15 27	20 35	25 45	30 50	35 55	40 65	45 70	50 75	55 80	60 85	70 100	75 105
Clearance group CN (norm.)		17 28	20 30	23 35	27 40	35 55	45 65	50 70	55 80	65 95	70 100	75 105	80 110	85 115	100 135	105 140
Clearance group C3		28 40	30 45	35 50	40 55	55 75	65 90	70 95	80 110	95 125	100 130	105 135	110 140	115 145	135 170	140 175
Clearance group C4		40 55	45 60	50 65	55 75	75 95	90 120	95 125	110 140	125 155	130 160	135 165	140 170	145 175	170 205	175 210

## 7.14 Axial Clearance of FAG Double Row Angular Contact Ball Bearings

### Series 32, 32B, 33 and 33B

		Dimensions in mm										
Nominal bore diameter	over to	6	10	18	24	30	40	50	65	80	100	120
		10	18	24	30	40	50	65	80	100	120	140

		Bearing clearance in microns										
Clearance group	min max	5	6	7	8	9	11	13	15	18	22	25
Clearance group C2	min max	11	12	14	15	16	18	22	24	26	30	34
Clearance group CN (norm.)	min max	21	23	25	27	29	33	36	40	46	53	59
Clearance group C3	min max	28	31	34	37	40	44	48	54	63	73	82
Clearance group C4	min max	45	47	48	50	54	58	63	71	83	96	108

### Series 32DA and 33 DA

		Bearing clearance in microns										
Clearance group	min max	5	6	7	8	9	11	13	15	18	22	25
Clearance group C2	min max	22	24	25	27	29	33	36	40	46	53	59
Clearance group CN (norm.)	min max	28	31	32	35	38	44	48	54	63	73	82
Clearance group C3	min max	37	41	42	46	50	58	63	71	83	96	108

# Tables

## 7.15 Axial Clearance of FAG Four-Point Bearings

Dimensions in mm

Nominal bore diameter	over to	<b>18</b>	<b>18</b>	<b>40</b>	<b>60</b>	<b>80</b>	<b>100</b>	<b>140</b>	<b>180</b>	<b>220</b>	<b>260</b>	<b>300</b>	<b>355</b>	<b>400</b>	<b>450</b>	<b>500</b>
-----------------------	---------	-----------	-----------	-----------	-----------	-----------	------------	------------	------------	------------	------------	------------	------------	------------	------------	------------

Bearing clearance in microns

Clearance group C2	min	20	30	40	50	60	70	80	100	120	140	160	180	200	220	290
	max	60	70	90	100	120	140	160	180	200	220	240	270	290	310	310

Clearance group CN (norm.)	min	50	60	80	90	100	120	140	160	180	200	220	250	270	290
	max	90	110	130	140	160	180	200	220	240	280	300	330	360	390

Clearance group C3	min	80	100	120	130	140	160	180	200	220	260	280	310	340	370
	max	120	150	170	180	200	220	240	260	300	340	360	390	430	470

Dimensions in mm

Nominal bore diameter	over to	<b>500</b>	<b>560</b>	<b>630</b>	<b>710</b>	<b>800</b>	<b>900</b>	<b>1000</b>
-----------------------	---------	------------	------------	------------	------------	------------	------------	-------------

Bearing clearance in microns

Clearance group C2	min	240	260	280	300	330	360
	max	330	360	390	420	460	500

Clearance group CN (norm.)	min	310	340	370	400	440	480
	max	420	450	490	540	590	630

Clearance group C3	min	400	430	470	520	570	620
	max	510	550	590	660	730	780

## 7.16 Radial Clearance Reduction of FAG Cylindrical Roller Bearings with Tapered Bore

Nominal bore diameter		Radial clearance prior to mounting						Reduction in radial clearance <sup>1)</sup>		Axial displacement on 1:12 taper <sup>1)</sup>				Smallest radial clearance after mounting		
d over mm	to mm	Clearance group CN (normal)		C3		C4		min mm	max mm	Shaft min mm	max mm	Sleeve min mm	max mm	CN min mm	C3 min mm	C4 min mm
		min mm	max mm	min mm	max mm	min mm	max mm									
24	30	0,035	0,06	0,045	0,07	0,055	0,08	0,015	0,02	0,3	0,35	0,3	0,4	0,02	0,025	0,035
30	40	0,04	0,065	0,055	0,08	0,07	0,095	0,02	0,025	0,35	0,4	0,35	0,45	0,02	0,025	0,04
40	50	0,045	0,075	0,06	0,09	0,075	0,105	0,025	0,03	0,4	0,45	0,45	0,5	0,02	0,03	0,045
50	65	0,05	0,08	0,07	0,1	0,09	0,12	0,03	0,035	0,45	0,55	0,5	0,65	0,02	0,035	0,05
65	80	0,06	0,095	0,085	0,12	0,11	0,145	0,035	0,04	0,55	0,6	0,65	0,7	0,025	0,04	0,07
80	100	0,07	0,105	0,095	0,13	0,12	0,155	0,04	0,045	0,6	0,7	0,65	0,8	0,03	0,05	0,075
100	120	0,09	0,13	0,115	0,155	0,14	0,18	0,045	0,055	0,7	0,85	0,8	0,95	0,045	0,065	0,085
120	140	0,1	0,145	0,13	0,175	0,16	0,205	0,055	0,065	0,85	1	0,95	1,1	0,045	0,07	0,095
140	160	0,11	0,16	0,145	0,195	0,18	0,23	0,06	0,075	0,9	1,2	1	1,3	0,05	0,075	0,105
160	180	0,125	0,175	0,16	0,21	0,195	0,245	0,065	0,085	1	1,3	1,1	1,5	0,06	0,08	0,11
180	200	0,14	0,195	0,18	0,235	0,22	0,275	0,075	0,095	1,2	1,5	1,3	1,7	0,065	0,09	0,125
200	225	0,155	0,215	0,2	0,26	0,245	0,305	0,085	0,105	1,3	1,6	1,4	1,8	0,07	0,1	0,14
225	250	0,17	0,235	0,22	0,285	0,27	0,335	0,095	0,115	1,5	1,8	1,6	2	0,075	0,105	0,155
250	280	0,185	0,255	0,24	0,31	0,295	0,365	0,105	0,125	1,6	2	1,7	2,3	0,08	0,125	0,17
280	315	0,205	0,28	0,265	0,34	0,325	0,4	0,115	0,14	1,8	2,2	1,9	2,4	0,09	0,13	0,185
315	355	0,225	0,305	0,29	0,37	0,355	0,435	0,13	0,16	2	2,5	2,2	2,7	0,095	0,14	0,195
355	400	0,255	0,345	0,33	0,42	0,405	0,495	0,14	0,17	2,2	2,6	2,5	2,9	0,115	0,165	0,235
400	450	0,285	0,385	0,37	0,47	0,455	0,555	0,15	0,185	2,3	2,8	2,6	3,1	0,135	0,19	0,27
450	500	0,315	0,425	0,41	0,52	0,505	0,615	0,16	0,195	2,5	3	2,8	3,4	0,155	0,215	0,31
500	560	0,35	0,47	0,455	0,575	0,56	0,68	0,17	0,215	2,7	3,4	3,1	3,8	0,18	0,24	0,345
560	630	0,38	0,5	0,5	0,62	0,62	0,74	0,185	0,24	2,9	3,7	3,5	4,2	0,195	0,26	0,38
630	710	0,435	0,575	0,565	0,705	0,695	0,835	0,2	0,26	3,1	4,1	3,6	4,7	0,235	0,305	0,435
710	800	0,485	0,645	0,63	0,79	0,775	0,935	0,22	0,28	3,4	4,4	3,9	5,3	0,26	0,35	0,495
800	900	0,54	0,71	0,7	0,87	0,86	1,03	0,24	0,31	3,7	4,8	4,3	5,5	0,3	0,39	0,55
900	1000	0,6	0,79	0,78	0,97	0,96	1,15	0,26	0,34	4,1	5,3	4,8	6,2	0,34	0,44	0,62
1000	1120	0,665	0,875	0,865	1,075	1,065	1,275	0,28	0,37	4,4	5,8	5,2	7	0,385	0,5	0,7
1120	1250	0,73	0,97	0,96	1,2	1,2	1,44	0,31	0,41	4,8	6,4	5,7	7,6	0,42	0,55	0,79
1250	1400	0,81	1,07	1,07	1,33	1,33	1,59	0,34	0,45	5,3	7	6,3	8,3	0,47	0,62	0,85

<sup>1)</sup> Valid only for solid steel shafts and hollow shafts whose bore diameter does not exceed half the shaft diameter.

Note: Bearings whose radial clearance is in the upper half of the tolerance range are mounted with the greater value of radial clearance reduction/axial drive-up distance. Bearings whose radial clearance is in the lower half of the tolerance range are mounted with the smaller value of radial clearance reduction/axial drive-up distance.

# Tables

## 7.17 Radial Clearance Reduction of FAG Spherical Roller Bearings with Tapered Bore

Nominal bore diameter d over to mm		Radial clearance prior to mounting Clearance group CN (normal) C3 C4 min max min max min max						Reduction in radial clearance <sup>1)</sup> min max mm		Axial displacement on 1:12 taper <sup>1)</sup>				Axial displacement on 1:30 taper <sup>2)</sup>				Smallest radial clearance after mounting		
										Shaft min max mm		Sleeve min max mm		Shaft min min mm		Sleeve min max mm		CN	C3	C4
		min	max	min	max	min	max	min	max	min	max	min	max	min	max	min	max	min	max	min
24	30	0,03	0,04	0,04	0,055	0,055	0,075	0,015	0,02	0,3	0,35	0,3	0,4	-	-	-	-	0,015	0,02	0,035
30	40	0,035	0,05	0,05	0,065	0,065	0,085	0,02	0,025	0,35	0,4	0,35	0,45	-	-	-	-	0,015	0,025	0,04
40	50	0,045	0,06	0,06	0,08	0,08	0,1	0,025	0,03	0,4	0,45	0,45	0,5	-	-	-	-	0,02	0,03	0,05
50	65	0,055	0,075	0,075	0,095	0,095	0,12	0,03	0,04	0,45	0,6	0,5	0,7	-	-	-	-	0,025	0,035	0,055
65	80	0,07	0,095	0,095	0,12	0,12	0,15	0,04	0,05	0,6	0,75	0,7	0,85	-	-	-	-	0,025	0,04	0,07
80	100	0,08	0,11	0,11	0,14	0,14	0,18	0,045	0,06	0,7	0,9	0,75	1	1,7	2,2	1,8	2,4	0,035	0,05	0,08
100	120	0,1	0,135	0,135	0,17	0,17	0,22	0,05	0,07	0,7	1,1	0,8	1,2	1,9	2,7	2	2,8	0,05	0,065	0,1
120	140	0,12	0,16	0,16	0,2	0,2	0,26	0,065	0,09	1,1	1,4	1,2	1,5	2,7	3,5	2,8	3,6	0,055	0,08	0,11
140	160	0,13	0,18	0,18	0,23	0,23	0,3	0,075	0,1	1,2	1,6	1,3	1,7	3	4	3,1	4,2	0,055	0,09	0,13
160	180	0,14	0,2	0,2	0,26	0,26	0,34	0,08	0,11	1,3	1,7	1,4	1,9	3,2	4,2	3,3	4,6	0,06	0,1	0,15
180	200	0,16	0,22	0,22	0,29	0,29	0,37	0,09	0,13	1,4	2	1,5	2,2	3,5	4,5	3,6	5	0,07	0,1	0,16
200	225	0,18	0,25	0,25	0,32	0,32	0,41	0,1	0,14	1,6	2,2	1,7	2,4	4	5,5	4,2	5,7	0,08	0,12	0,18
225	250	0,2	0,27	0,27	0,35	0,35	0,45	0,11	0,15	1,7	2,4	1,8	2,6	4,2	6	4,6	6,2	0,09	0,13	0,2
250	280	0,22	0,3	0,3	0,39	0,39	0,49	0,12	0,17	1,9	2,6	2	2,9	4,7	6,7	4,8	6,9	0,1	0,14	0,22
280	315	0,24	0,33	0,33	0,43	0,43	0,54	0,13	0,19	2	3	2,2	3,2	5	7,5	5,2	7,7	0,11	0,15	0,24
315	355	0,27	0,36	0,36	0,47	0,47	0,59	0,15	0,21	2,4	3,4	2,6	3,6	6	8,2	6,2	8,4	0,12	0,17	0,26
355	400	0,3	0,4	0,4	0,52	0,52	0,65	0,17	0,23	2,6	3,6	2,9	3,9	6,5	9	5,8	9,2	0,13	0,19	0,29
400	450	0,33	0,44	0,44	0,57	0,57	0,72	0,2	0,28	3,1	4,1	3,4	4,4	7,7	10	8	10,4	0,13	0,2	0,31
450	500	0,37	0,49	0,49	0,63	0,63	0,79	0,21	0,26	3,3	4,4	3,6	4,8	8,2	11	8,4	11,2	0,16	0,23	0,35
500	560	0,41	0,54	0,54	0,68	0,68	0,87	0,24	0,32	3,7	5	4,1	5,4	9,2	12,5	9,6	12,8	0,17	0,25	0,36
560	630	0,46	0,6	0,6	0,76	0,76	0,98	0,26	0,35	4	5,4	4,4	5,9	10	13,5	10,4	14	0,2	0,29	0,41
630	710	0,51	0,67	0,67	0,85	0,85	1,09	0,3	0,4	4,6	6,2	5,1	6,8	11,5	15,5	12	16	0,21	0,31	0,45
710	800	0,57	0,75	0,75	0,96	0,96	1,22	0,34	0,45	5,3	7	5,8	7,6	13,3	17,5	13,6	18	0,23	0,35	0,51
800	900	0,64	0,84	0,84	1,07	1,07	1,37	0,37	0,5	5,7	7,8	6,3	8,5	14,3	19,5	14,8	20	0,27	0,39	0,57
900	1000	0,71	0,93	0,93	1,19	1,19	1,52	0,41	0,55	6,3	8,5	7	9,4	15,8	21	16,4	22	0,3	0,43	0,64
1000	1120	0,78	1,02	1,02	1,3	1,3	1,65	0,45	0,6	6,8	9	7,6	10,2	17	23	18	24	0,32	0,48	0,7
1120	1250	0,86	1,12	1,12	1,42	1,42	1,8	0,49	0,65	7,4	9,8	8,3	11	18,5	25	19,6	26	0,34	0,54	0,77
1250	1400	0,94	1,22	1,22	1,55	1,55	1,96	0,55	0,72	8,3	10,8	9,3	12,1	21	27	22,2	28,3	0,36	0,59	0,84

<sup>1)</sup> Valid only for solid steel shafts and hollow shafts whose bore diameter does not exceed half the shaft diameter.

Note: Bearings whose radial clearance is in the upper half of the tolerance range are mounted with the greater value of radial clearance reduction/axial drive-up distance. Bearings whose radial clearance is in the lower half of the tolerance range are mounted with the smaller value of radial clearance reduction/axial drive-up distance.

## 7.18 FAG Rolling Bearing Greases Arcanol – Chemico-physical data and directions for use

Grease	Thickener	Base oil viscosity at 40°C mm <sup>2</sup> /s	Consistency NLGI Class	Operating temperature °C	Main characteristics	Typical applications
<b>MULTITOP</b> (so far L135V)	Lithium soap with EP additives	85	2	-40...+150	Universal grease for bearings at increased speeds, high loads, low and high temperatures	Rolling mills, construction machines, cars, spinning and grinding spindles
<b>MULTI2</b> (so far L78V)	Lithium soap	ISO VG 100	2	-30...+140	Universal grease for ball bearings with Ø D ≤ 62 mm	small electric motors, agricultural and construction machines, household appliances
<b>MULTI3</b> (so far L71V)	Lithium soap	80	3	-30...+140	Universal grease for ball bearings with Ø D > 62 mm	large electric motors, agricultural and construction machines, blowers
<b>LOAD220</b> (so far L215V)	Lithium/ calcium soap with EP additives	ISO VG 220	2	-20...+140	Special grease for bearings at high loads, large speed range, high degree of humidity	Rolling mills, rail vehicles
<b>LOAD400</b> (so far L186V)	Lithium/ calcium soap with EP additives	400	2	-25...+140	Special grease for bearings at extreme loads, medium speeds, medium temperatures	Mining machines, construction machines
<b>LOAD1000</b> (so far L223V)	Lithium/ calcium soap with EP additives	ISO VG 1000	2	-20...+140	Special grease for bearings at extreme loads, medium temperatures, low speeds	Mining machines, construction machines, preferably for shock loads and large bearings
<b>TEMP90</b> (so far L12V)	Calcium polyurea with EP additives	130	2	-40...+160	Special grease for bearings at high temperatures, high loads	Couplings, electric motors, cars
<b>TEMP110</b> (so far L30V)	Lithium complex soap	ISO VG 150	2	-40...+160	Special grease for bearings at high temperatures, high speeds	Electric machines, cars
<b>TEMP120</b> (so far L195V)	Polyurea with EP additives	ISO VG 460	2	-35...+180	Special grease for bearings at high temperatures, high loads	Continuous casting plants
<b>TEMP200</b> (so far L79V)	PTFE	400	2	-40...+260	Special grease for bearings at extremely high temperatures (safety advice page 60), chemically aggressive environment	Support rollers in baking machines, piston pins in compressors, kiln trucks, chemical plants
<b>SPEED2,6</b> (so far L75)	Polyurea	ISO VG 22	2-3	-50...+120	Special grease for ball bearings at extremely high speeds, low temperatures	Machine tools, instruments
<b>VIB3</b> (so far L166V)	Lithium complex soap with EP additives	170	3	-30...+150	Special grease for bearings at high temperatures, high loads, oscillating motion	Blade adjusters in rotors of wind power plants, packing machines
<b>BIO2</b>	Lithium/ calcium soap	58	2	-30...+140	Special grease for bearings in environmentally hazardous applications	
<b>FOOD2</b>	Aluminium complex soap	192	2	-30...+120	Special grease for bearings in applications with food contact; USDA H1	

# Fundamental Course

## Mounting Cabinet and Mounting Sets – Fundamental Course for Vocational Training

Plenty of literature is available on the correct mounting of rolling bearings. In most cases, however, the apprentices lack means and components for practical training. Therefore, the instructors of the FAG apprentice shops have prepared a fundamental course.

The target of this fundamental course is to impart the knowledge of the selection of the suitable bearing, appropriate mounting and dismounting, and maintenance. Therefore, the course has two parts.

The theoretical part deals with rolling bearing fundamentals, the practical part with the basic skill required for mounting and dismounting.

For the theoretical part, great store has been set by reasonably combining technical drawing, arithmetic, and instruction in mechanical engineering. For the practical part, simplified models of the mating parts of rolling bearings (shafts and housings) are available by means of which the mounting and dismounting of the current bearing types can be practised with mechanical and hydraulic equipment.

The subjects taught are based on instruction records and do not exceed the degree of difficulty required today in vocational training.

Based on this fundamental course, other units such as transmissions, pumps, spindles, motor car wheels etc. can be prepared for practical training.

### Technical Data

Mounting cabinet:

Dimensions 1135x710x380 mm

Weight (with contents) 94 kg

suitable for 10 mounting exercises:

5 with shafts, 2 with housings,

3 with shafts and housings

Smallest shaft diameter 15 mm

Largest shaft diameter 55 mm

Angle plate: Dimensions 500x300x300 mm

Weight 40 kg

### Manual 1 (Theoretical Part)

Instructions in mechanical engineering

Technical arithmetic

Technical drawing

### Manual 2 (Practical Part)

Mounting of bearings with cylindrical bore

Mounting of bearings with tapered bore

Hydraulic technique

Mounting of heated bearings

Practical training with shafts and housings

In addition to the mounting cabinet with contents and the mounting angle also single mounting sets can be ordered, see Publ. No. WL 80 111.

Please direct enquiries and orders to

### FAG Industrial Services

P.O. Box 12 60 · D-97419 Schweinfurt

Phone +49 97 21/91 36 91 · Telefax +49 97 21/91 38 09

<http://www.fag.com>



## 7.23 FAG Rolling Bearing Greases Arcanol – Chemico-physical data and directions for use

Grease	Thickener	Base oil viscosity at 40°C mm <sup>2</sup> /s	Consistency NLGI Class	Operating temperature °C	Main characteristics	Typical applications
<b>MULTITOP</b> (so far L135V)	Lithium soap with EP additives	85	2	-40 ... +150	Universal grease for bearings at increased speeds, high loads, low and high temperatures	Rolling mills, construction machines, cars, spinning and grinding spindles
<b>MULTI2</b> (so far L78V)	Lithium soap	ISO VG 100	2	-30 ... +140	Universal grease for ball bearings with øD ≤ 62 mm	small electric motors, agricultural and construction machines, household appliances
<b>MULTI3</b> (so far L71V)	Lithium soap	80	3	-30 ... +140	Universal grease for ball bearings with øD > 62 mm	large electric motors, agricultural and construction machines, blowers
<b>LOAD220</b> (so far L215V)	Lithium/calcium soap with EP additives	ISO VG 220	2	-20 ... +140	Special grease for bearings at high loads, large speeds range, high degree of humidity	Rolling mills, rail vehicles
<b>LOAD400</b> (so far L186V)	Lithium/calcium soap with EP additives	400	2	-25 ... +140	Special grease for bearings at extreme loads, medium speeds, medium temperatures	Mining machines, construction machines
<b>LOAD1000</b> (so far L223V)	Lithium/calcium soap with EP additives	ISO VG 1000	2	-20 ... +140	Special grease for bearings at extreme loads, medium temperatures, low speeds	Mining machines, construction machines, preferably for shock loads and large bearings
<b>TEMP90</b> (so far L12V)	Calcium polyurea with EP additives	130	2	-40 ... +160	Special grease for bearings at high temperatures, high loads	Couplings, electric motors, cars
<b>TEMP110</b> (so far L30V)	Lithium complex soap	ISO VG 150	2	-40 ... +160	Special grease for bearings at high temperatures, high speeds	Electric machines, cars
<b>TEMP120</b> (so far L195V)	Polyurea with EP additives	ISO VG 460	2	-35 ... +180	Special grease for bearings at high temperatures, high loads	Continuous casting plants
<b>TEMP200</b> (so far L79V)	PTFE	400	2	-40 ... +260	Special grease for bearings at extremely high temperatures, (safety advice page 60), chemically aggressive environment	Support rollers in baking machines, piston pins in copressors, kiln trucks, chemical plants
<b>SPEED2,6</b> (so far L75)	Polyurea	ISO VG 22	2-3	-50 ... +120	Special grease for ball bearings at extremely high speeds, low temperatures	Machines tools, instruments
<b>VIB3</b> (so far L166V)	Lithium complex soap with EP additives	170	3	-30 ... +150	Special grease for bearings at high temperatures, high loads, oscillating motions	Blade adjusters in rotors of wind power plants, packing machines
<b>BIO2</b>	Lithium/calcium soap	58	2	-30 ... +120	Special grease for bearings in environmentally hazardous applications	
<b>FOOD2</b>	Aluminium complex soap	192	2	-30 ... +120	Special grease for bearings in applications with food contact; USDA H1	

---

The logo consists of the letters 'FAG' in a bold, outlined, sans-serif font, enclosed within a rectangular border.

Rolling Bearings

---

## Mounting and Dismounting of Rolling Bearings

Every care has been taken to ensure the correctness of the information contained in this publication but no liability can be accepted for any errors or omissions.

We reserve the right to make changes in the interest of technical progress.

© by FAG 2004 · This publication or parts thereof may not be reproduced without our permission.

**WL 80 100/3 EC/ED/94/05/04** · Printed in Germany by Weppert GmbH & Co. KG, Schweinfurt